

OPERATION & MAINTENANCE MANUAL

For Motor Technical/Service related query, address your enquires at :

Addl. General Manager
Industrial machines Sales Division
Bharat Heavy Electricals Ltd.
Piplani, Bhopal (M.P.) - 462 022
Tele fax : 0755-2500963
website : www.bhelbhopal.com

For Motor price quotation, address your enquires at :

Addl. General Manager
Industry Sector
Integrated Office Complex
Lodhi Road, New Delhi-110 003
Fax : 011-24365367

For Motor spares quotation, address your enquires at :

Addl. General Manager
Electrical Machine Repair Plant
Plot No. D/1, Cross Road-C
Road No. 16, MIDC, Andheri (East)
Mumbai-400 093
Tele fax : 022-28364587

Note : Product development & Improvement are our continuous endeavour, hence the product may slightly differ from that indicated in this manual

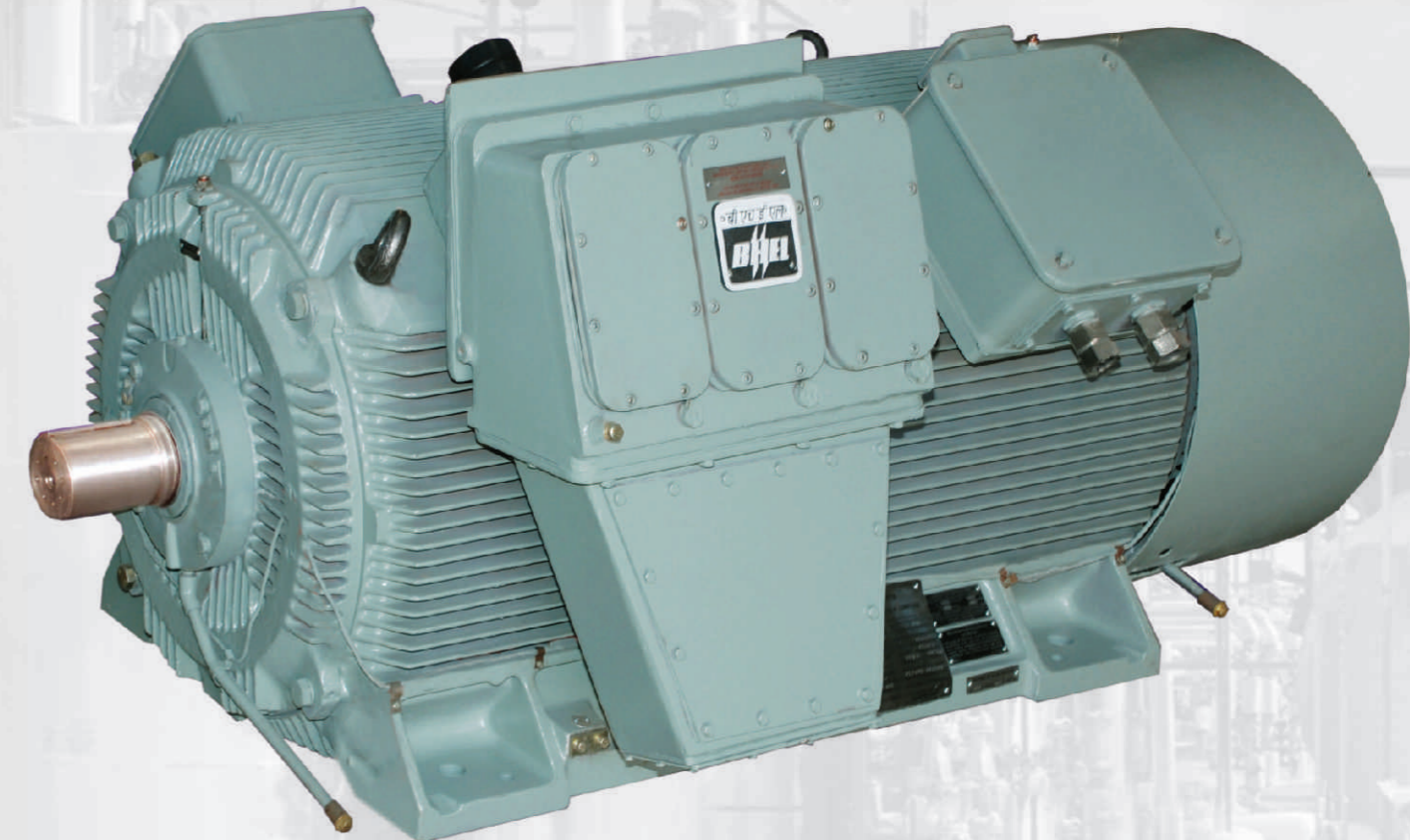
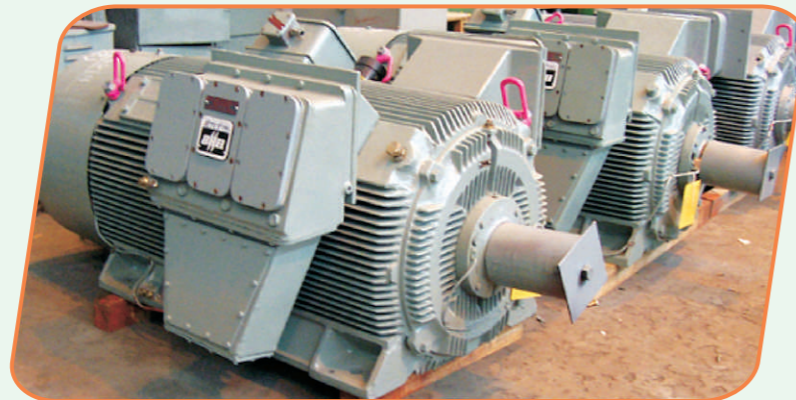

H - COMPACT MOTORS

ZOOM GRAPHICS # 9827258731



Bharat Heavy Electricals Limited

PIPLANI, BHOPAL (M.P.) - 462 022



INDUSTRIAL MACHINES SALES DIVISION

Bharat Heavy Electricals Limited

B H O P A L

*Operation &
Maintenance Manual*
For
H - COMPACT MOTORS

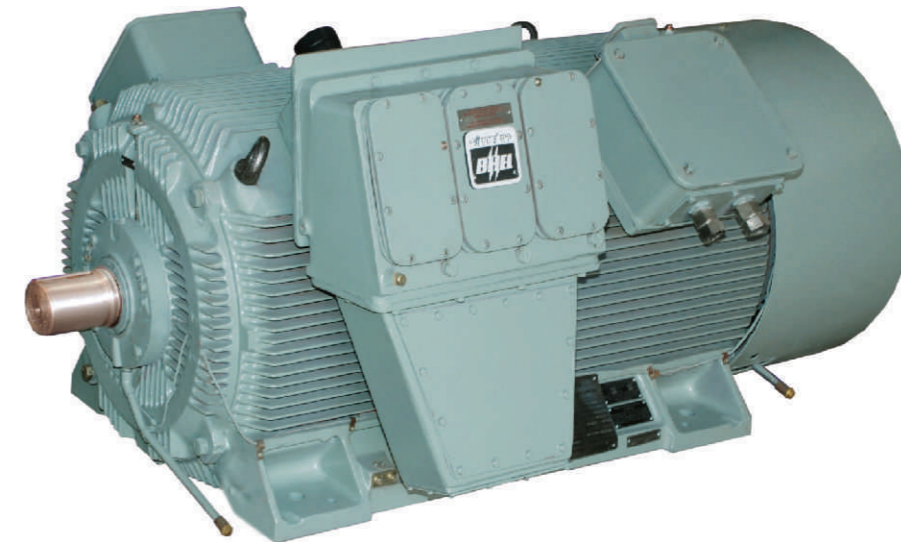

INDUSTRIAL MACHINES SALES DIVISION
BHARAT HEAVY ELECTRICAL LIMITED
BHOPAL

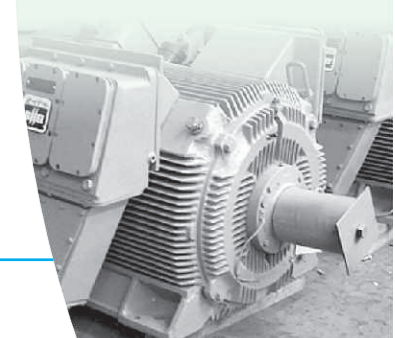

INDEX

	Page No.
CHAPTER - 1. DESCRIPTION OF MACHINE	1
General Stator, Rotor, bearings, terminal box PSTB, Anti - condensation heaters, Resistance Temperature Detector	
CHAPTER - 2. RECEIPT, INSPECTION AND STORAGE	10
CHAPTER - 3. INSTALLATION	13
General Methods of installation, Alignment of Drives, Measuring the insulation resistance. Drying of windings	
CHAPTER - 4. OPERATION	19
Commissioning, Operation and shutting down Starting the machine, Operation, Shutting down	
CHAPTER - 5. MAINTENANCE	22
Maintenance & inspection schedule for mechanical machine parts, Maintenance & inspection schedule for stator windings, Maintenance of windings	
CHAPTER - 6. DISMANTLING AND REASSEMBLY PROCEDURE	29
CHAPTER - 7. FAULT DIAGNOSIS CHART	33
CHAPTER - 8. PRESERVATION MEASURES	35
CHAPTER - 9. SAFETY PRECAUTIONS	37
CHAPTER - 10. ENVIRONMENTAL GUIDE LINES	39
CHAPTER - 11. LIST OF RECOMMENDED SPARES	40

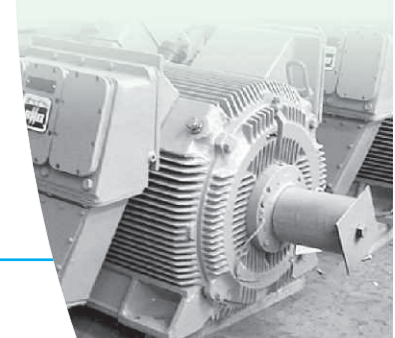

CHAPTER 1

DESCRIPTION OF MACHINE

THREE PHASE A.C. MOTORS

1 LA4

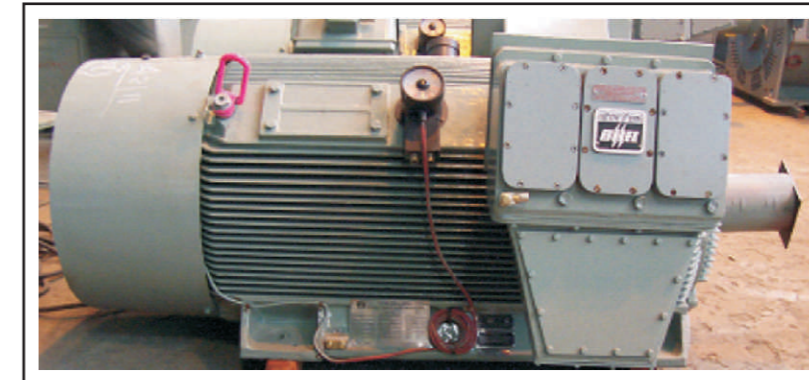

1.1 Introduction :

This O & M manual gives description of Totally Enclosed Fan Cooled 3-phase Squirrel Cage Induction motors. Closed type motors conforming to IP54 / IP55 protection have frame designation beginning as "1LA4". These motors generally comply with all relevant Indian and International Standards on rotating electrical machines like IS325, IEC 34. The machines are suitable either for horizontal mounting (B3) or vertical mounting (V10).

This manual enables user to know the machine in respect of construction, storage, operation and maintenance of motors of this type having a wide range of output from smallest to highest frame but without any dimension details. To know external dimension details & performance parameters of any specific motor, user has to refer to Outline & General Arrangement Drawing and Technical Data sheets submitted by vendor.

1.2 Ventilation / Cooling Arrangement :

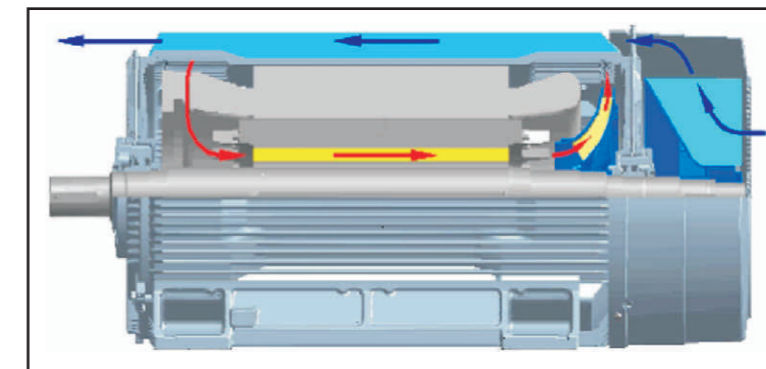

The 1LA4 motors have two shaft-mounted fans, one for internal air circulation and the other for external atmospheric air circulation. The external fan blows the cool air through external ribs over the frame surface.

The shaft-mounted fans will usually have a fixed direction of rotation only. Fans suitable for both directions of rotation can be provided if specifically ordered.

Stator frame and winding

The stator winding is a chorded double layer winding and is connected in star. The star point is formed on the winding, or can be made outside. The stator winding can be designed with 'Delta' connections also as per request.

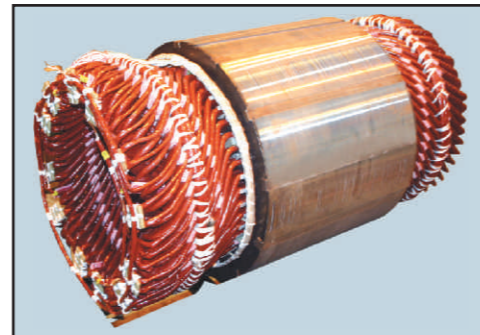

The conductor strands consist of electrolytic copper and have a rectangular cross section. The coils are inserted in the open slot of core. The slots are closed off by a magnetic material. The uniform air gap field makes for small pulsation and surface losses, and thus for a high efficiency. The magnetic slot seal also reduces the starting current and the noise.

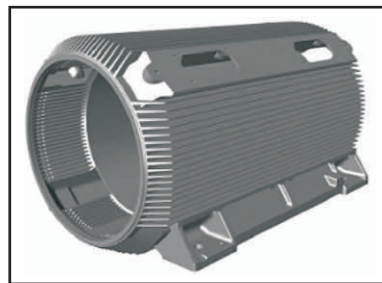

The stator winding is a double-layer coil winding and is provided with MICALASTIC[®] insulation complying with class F insulation requirements. This insulation system is based on integrated mica and is made by a special synthetic resin impregnation process. The insulation possesses high electric strength, high resistance to moisture and aggressive gases and vapors, excellent mechanical stability and long life.

The stator frame is made out of cast steel.

The stator core pack is shrink fitted centrally in the stator frame thus it is secured against rotation and displacement.

The stator core pack is shrink fitted centrally in the stator frame thus it is secured against rotation and displacement.

Rotor

The shafts have two journals (drive end and non-drive end) and a cylindrical shaft extension at the drive end. A second shaft extension may be provided at the non-drive end.



The laminated rotor core is pressed on to the shaft and clamped & secured against axial displacement and carries Sq. Cage winding, The cage bars are with special profile and are inserted firmly seated in the slots of rotor core. They are connected to short circuiting rings by induction brazing. The rotors are dynamically balanced with half parallel key inserted in the key way of shaft extension.

End shields

The end shields at the drive and non-drive ends are disk shaped casting and arranged for taking the bearing assembly which is appropriate for the type and type variant of the machine.



External Fans

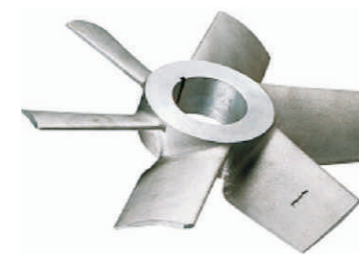

Bearings

Depending on the design and the operating conditions specified in the order, the machines are fitted with grease-lubricated rolling-contact bearings or with sleeve bearings with or without forced-oil lubrication.

Sleeve bearings of machines of the floating type without axial restraint. Axial restraint for the rotors of such machines must be provided from the locating bearing of the driven machine via a suitable coupling having limited play. For a full description & sketch and special instructions, refer to chapter 5 maintenance instructions.

Bearing Arrangement in Horizontal Motors

A) 2 Pole	DE Side	NDE Side
Frame 31., 35., 40.	Single AF bearing	Single AF bearing
Frame 45., 50., 56.	Sleeve bearing	Sleeve bearing
B) 4 Pole & Above		
Frame 31., 35., 40.	Single AF bearing	Single AF bearing
Frame 45., 50., 56.	Two AF bearing	Single AF bearing

AF - Anti-friction bearing

Lubrication - AF Bearing - Grease Lubricated
Sleeve Bearing - Flood Oil Lubricated

Bearing Arrangement in Vertical Motors

	DE (Bottom)	NDE (Bottom)
Frame 31., 35., 40., 45., 50., 56.	Deep groove ball bearing	Angular contact ball bearing

Terminal boxes :

The electrical connections of the stator and rotor windings are made in separate terminal boxes. Any auxiliary circuits for functions such as anti-condensation heating, temperature monitoring, etc. are connected in additionally fitted auxiliary terminal boxes. The terminal boxes at least comply with degree of protection IP 54 to IS-4629 or IEC 34-5.

The number, location and type of terminal boxes can be seen from the dimension drawing of the machine; the kind, circuit arrangement and connections of the main and auxiliary circuits are documented in the accompanying circuit diagrams.

STATOR TERMINAL BOX AND ARRANGEMENT

(For High Voltage Motors)

Phase-Segregated Terminal Arrangement :

When a high fault capacity Phase-Segregated Terminal Box is fitted to a machine connected to a high fault level system, the incoming supply cables is terminated in the Terminal Box itself. The connection between the motor and supply cable is by means of split cable clamp provided along with the box. The cable tails terminate with copper ferrules and a set of 3 ferrules is supplied for fitting to the tails of the incoming supply cables. It is normal to leave a 3 mm gap between the clamped tail cable ends. If desired the clamps and ferrules from both motor and supply cables can be omitted and the joints made by crimped connectors.

Each terminal box is provided with three desiccators. On examination, the desiccators when dry, show the inner ring of the indicator to be blue in color. If this inner ring show up pink in contrast to the blue outer ring, the desiccators will have to be dried out and refitted.

PHASE SEGREGATED TERMINAL ARRANGEMENT

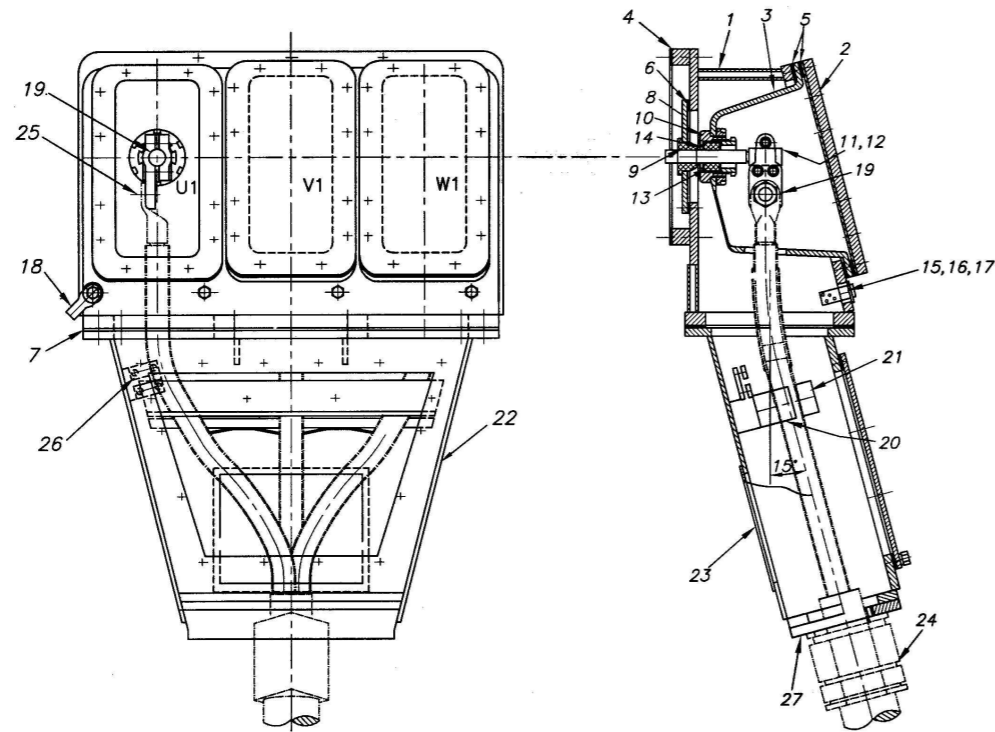
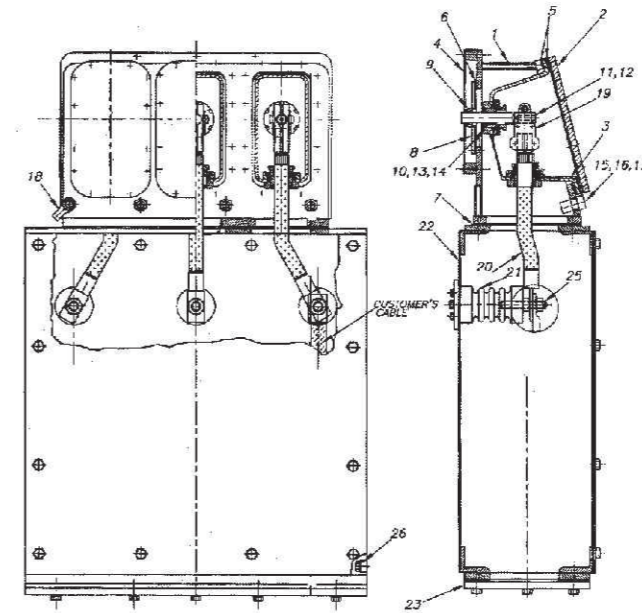

Table of fittings					
Sn.	Description	Material	Sn.	Description	material
01	Terminal box	Steel	14	Split washer	Bakelite fabric board
02	Lid	Steel with FRP lining	15	Desicator	Assembly
03	Joint box	FRP Moulding	16	Tub. socket (for 14 Ø) earthing pad earthing pad (for MS Flat)	For earthing copper
04	Gasket	Neoprene Rubber			
05	Gasket	Neoprene Rubber	17	Terminal connector	Brass
06	Gasket	Neoprene Rubber	18	Bottom clamp	Epoxy glass mat laminated sheet
07	Gasket	Neoprene Rubber	19	Top clamp	
08	Sealing plate	Bakelite paper board	20	Trifurcating box	Steel
09	Grommet	Neoprene Rubber	21	Pressure relief diaphragm	Bakelite board
10	Gland part	Nylon	22	Double comp cable gland	Brass nickel plated
11	Ferrule for stator cable	Copper	23	Bolt M16 with locking plate	Steel
12	Filler pin	Steel	24	Earthing pad for 50x6 GI flat	Steel
13	Gland bush	Synthetic rubber	25	Gland plate	Steel

PHASE SEPERATED TERMINAL ARRANGEMENT



QTY.	IT. No.	DESCRIPTION
01	01	P.S. TERMINAL BOX (STEEL)
03	02	TERMINALS
01	03	TRIFURCATING BOX. (STEEL)
10	04	HEX. SCREW M10X30 - 8.8
20	05	WASHER SPRING B 10-ST
01	06	GASKET (NEOPRENE RUBBER)
01	07	GASKET (NEOPRENE RUBBER)
01	08	ADAPTOR (STEEL)
10	09	HEX. SCREW M10 X 50-8.8
02	10	EATHING PAD (STEEL WITH ZINC PLATING)
01	11	TUBULAR LUB SOCKET TYPE I-11E
01	12	HEX SCRUC M12 X 30 P-8.8
01	13	WASHER M CD 13-ST
01	14	WASHER SPRING B 12-ST
03	15	DESSICATOR
03	16	INSULATION PLATE
03	17	JOINT BOX (GRP MOULDING)
01	18	GLAND PLATE (STEEL)

Anti Condensation Heating Description

Application

Anti condensation heaters are fitted in the motors to warm the air inside the stationary machine above that of the surroundings, thus effectively preventing moisture condensation.

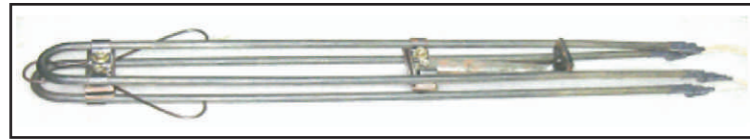

Installation

Depending on the size and type of the machine the anti-condensation heater consists of two or more heating tubes connected together. They are combined to form units which are normally built into the stator frame air pockets. The heating tubes have a heating conductor which is embedded in insulating material and arranged inside a corrosion-resistant metal tube. The tube ends are sealed to prevent ingress of moisture.

Connecting

The heater connections are brought to terminals which are located in a separate terminal box in the case of high-voltage machines.

Connection must be made in accordance with the diagram shown in the terminal box. Examine the rating plate or the text of the dimension drawing to see that the voltage and the power of the heaters. The supply connection of the heaters must be interlocked with the main breaker of the machine to ensure that the heaters are switched off when the machine is running and switched on once the machine has come to a standstill.

Maintenance

Important

When the machine has come to a standstill the anti-condensation heating is switched on. Therefore the heating must also be switched off before the maintenance begins inside the machine.

Cleaning

The maintenance is limited to the cleaning corresponding to the normal maintenance of the machine and to the replacement of damaged parts.

Repairs

Should replacement of the heating tubes become necessary use the same type of heaters. Install the new tubes securely and lock the fixing elements.

Resistance Temperature Detector

Stator Winding

Description

The temperature of the stator winding is monitored by resistance thermometers embedded in the stator winding to protect the winding against thermal over loads.

Thermal overloading means a prolonged excess temperature which may destroy the winding insulation or considerably reduce the life of the insulation.

If the winding temperature at the points where the temperature sensors are installed reaches or exceeds the permissible limit value an alarm signal is given or the machine shut down automatically, depending on the temperature attained and type of protection provided by user.

The temperature sensors are installed in separators of the stator winding. Replacement of the sensors would be difficult.

The number of sensors and their distribution over the slots in the stator is indicated in the dimension drawing.

The connecting leads of the temperature sensors are taken to an auxiliary terminal box. The circuit arrangement and the terminal connections can be seen from the diagram shown in the auxiliary terminal box which forms part of the dimension drawing of the machine.

Commissioning

Before commissioning the machine. Check all the leads for correct connection by reference to the circuit diagram.

Important

The maximum load permitted for the resistance thermometers Pt 100 (100° at 0° c) is 10 mA. Only use a single button Wheatstone bridge for testing.

Note

The temperature monitoring system of the stator winding does not provide complete thermal protection for the entire machine. Owing to the different time constants, parts of the rotor winding may assume a high temperature earlier than the measuring points in the stator winding under conditions of rapidly varying loads.



RECEIPT, INSPECTION AND STORAGE

GENERAL INSTRUCTIONS

The rotor of the 'Machine is locked in position for transport by a shaft block to prevent damage to the bearing. Do not remove this shaft block until the transmission element is fitted. Other measures may be necessary in special cases if the machine is to be transported after the transmission element is fitted.

Machines of vertical type of construction should be transported in a vertical position. In exceptional cases in which machines with angular-contact ball bearings have to be transported horizontally, lock the rotor by a shaft block before carefully moving the machine into a horizontal position. When setting down the machine, make sure that a safeguard is provided to prevent it rolling away, also ensure that the machine is set down squarely only on the flanges of the stator frame because the shell is not designed to take the full weight of the machine. If a machine is not put into service immediately after arrival, store it in a dry, vibration-free room.

2:1 GENERAL

The machines have been carefully inspected and packed before leaving the factory. After receipt the machine should be removed carefully from its packing and examined thoroughly to see if damage has occurred in transit. Ensure that all parts and accessories are in accordance with packing slip and in proper condition. In the event of any damage or loss in transit the carriers and manufacturer should be advised in writing within the stipulated period.

If goods sent overseas are received in damaged or incomplete condition the communication either to the Insurance Company or to ourselves should be accompanied with surveyor's report and the photographs or other useful evidence.

2.2 INSPECTION

After unpacking the machine should be cleaned to remove all dust and remnants of packing materials and all parts should be inspected thoroughly to ensure that nothing has become loose or detached due to vibrations or interference during transit.

2.3 SHORT TERM STORAGE

If the motor is not to be installed immediately it should be stored in clean, dry and covered area which is not subjected to large variation of temperature.

The condensation of moisture on windings lowers the insulations resistance. This should be avoided. Space heaters are intended to be in operating whenever the motor is switched off and subject to moisture and condensation.

Ensure that all covers are fitted intact and nothing is left open on the frame. Protective axial locking cover on shaft extension should be used to prevent damage to shaft extension.

2.4 LONG STORAGE

On arrival of motor at the destination, packages should be examined to determine whether moisture of any kind has entered. After unpacking the machine should be cleaned and thoroughly inspected to see that nothing is loose or detached due to vibration or interference during transit. If the package seems undamaged, it is reasonable to expect that the enclosed machine will be dry. Measure the insulation resistance of winding by means of megger. If, it is less than specified value than the motor should be dried out as detailed Section 3. If, it is suspected that moisture of any kind has entered into the motor winding then the motor should be dried out irrespective of IR value to earth. The motor should be stored in clean, warm, dry and sheltered building. Humid surroundings must be avoided. Failure to do so may lower the insulation resistance. The storage room should be well ventilated and reliably protected against ingress of atmospheric sedimentation. Earthen floors shall not be used. Relative humidity of air should not exceed 70% and the temperature not below + 10 deg C. There shall be no sharp variations in the relative humidity and the temp of air conditions.

No chemicals, acids, alkalis or storage batteries shall be stored in the same location with motors. It is necessary to cover the motor with thick water proof polythene covers with silica gel placed inside. The condition of silica gel for indication of presence of moisture should be checked periodically.

The motor should not be placed on a vibrating floor or in closed proximity of vibrating machinery. If this cannot be avoided, then the motor should be placed on thick blocks of rubber or felt and the shaft turned through a quarter of revolution each month. Space heaters should be put ON whenever motor is idle and is subjected to moisture and condensation.

Ensure that all covers are fitted intact and nothing is left open in the frame. It is to be removed only for turning the shaft through a quarter of revolution as described above and then put back in position. The bearing should be re-lubricated if the time between delivery and commissioning of the machine is more than 4 years, assuming that they have been stored in favorable conditions (i.e. in a dry, dust and vibration free room) or more than 2 years they have been stored in unfavorable conditions.

2.5 CARE OF BEARINGS

STATIONARY VIBRATION

If a machine fitted with roller bearings is subjected to continued vibration for long period while stationary, damage to the rollers and races may be caused by fretting corrosion (commonly called "Stationary Vibration", "Static Vibration Marking" or "False Brinelling").

The following precautions should therefore be taken :-

- Machines fitted with roller bearings should not be allowed to stand on vibrating floor during storage or operation, if this can be avoided.
- If storage on a vibrating floor cannot be avoided, the machine should be placed on thick blocks of rubber, cork or felt, and the rotor turned through about a quarter of a revolution each week. If a shroud/shaft locking device is fitted, it should be temporarily removed and refitted.
- When a machine fitted with roller bearings is installed as a stand by and is subjected to the adverse condition referred to above, IT IS ESSENTIAL that the rotor be turned as stipulated in (b) above.
- Similar damage to rollers and races sometimes occurs in transit, particularly on board ship. When machines are sent abroad the first recommendation given in note (b) above should be observed.



CHAPTER 3

INSTALLATION

GENERAL

Before beginning installation of the machine, carefully check all the foundation dimensions. Check the size and location of the holes for the anchor bolts and of duct for piping, cables and ventilation are correct. If a check is carried out at this stage, any inaccuracies can still be covered.

Remove the shaft block provided to block the rotor movement during transportation.

Examine the rating plate data to see that they agree with the power circuit to which the machine is to be connected. Select the size of the supply cable as required for the particular current rating. Connect the supply - cable conductors in accordance with the diagram shown in the terminal box.

Align the machine with coupled machine both axially and radially. Axial and radial readings shall be within permissible limits as under :

Permissible tolerance	Radial run out (mm)	Axial run out (mm)
Rigid coupling	0.03	0.02
Flexible coupling	0.05	0.05
	Refer coupling manufacturer instruction also	

Machines with sleeve bearings having axial float are supplied with magnetic pointer indicator fitted on either of DE or NDE bearing (preferably on the DE bearing of the machine) Length of the magnetic pointer has been adjusted at BHEL works to ensure that the stator and rotor are magnetically aligned, when the pointer is in line with the corresponding groove made in the shaft as shown in the figure below :

- Pointer
(In Case of two sleeve bearings without axial location)
- Bearing housing upper part
- Shaft

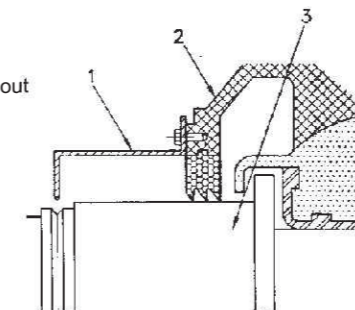

MAGNETIC CENTER POINTER

3.1 Checks before closing the terminal box

- The interior of the terminal box is clean and free of cable residue;
- All terminal screws or bolts are firmly tightened;
- The minimum clearances in air are maintained (more than 10 mm for 500V, more than 14 mm for 1 kV. and more than 60 mm for 6.6 kV, note any projecting wire ends).
- Unused entry openings are closed off with the plugging elements firmly screwed- in;
- For maintaining the degree of protection, all sealing, surfaces of the terminal box are in order. if sealing of the joints is effected by metal to metal joints only, these surfaces should be cleaned and thinly re-greased.

Before starting and during operation make sure that all relevant safety regulations are complied with.

3.2 Measuring the insulation resistance and Drying of windings

Before commissioning and after long periods of storage or stand-still, the insulation resistance of the windings to the frame must be measured with DC-voltage. Do not discontinue measurement, before the final value is indicated (With high voltage machines, this process may take up to 1 minute).

The limit values of minimum insulation resistance and critical insulation resistance (for measurement at a winding temperature of 25 deg C) and for measuring voltage can be derived from following table depending on rated voltage of machine.

	Limit Value at rated Voltage	
	<2 KV	>2 KV
Measuring Voltage	500 V DC (Min.100V DC)	500 V DC (Max.1000 V DC)
Minimum Insulation resistance with new, cleared or repair winding	10 Megohm	100 Megohm
Critical specific insulation resistance after long periods of operation	0.5 Megohm / KV	5 Megohm / KV

Dry new winding have insulation resistance values between 100 megaohm to 2000 megaohm or higher. If the insulation resistance value is in the region of minimum value, damp and/or dirt can be the cause. If the insulation resistance falls below the minimum value the cause must be established and the winding dried. The insulation resistance for clean winding is largely depended on temp. For each 10 deg C rise in temperature it falls by half i.e. with temperature rise of 50 deg C it falls to about 1/30 of initial value.

During operation the insulation resistance of winding may decrease as a result of environmental and operating condition. The critical specific insulation resistance at 25 deg C can be calculated depending on rated voltage using above table. If the value is above the critical values machines can be operated further. If the value is reached below the critical value winding must be thoroughly cleaned and dried.

3.3 Polarization Index Check

The polarization index (PI) is a figure of merit for dryness and cleanliness of the winding insulation. PI is ratio of two measurements of insulation resistance taken at specified time interval employing the same measuring condition (Identical winding . temperature and Identical measuring voltage).

PI = IR 10 Min IR 1 Min The procedure for evaluation of the	Based on PI	Drying
Hazardous	< 1	Mandatory
Bad	1-1.5	Mandatory
Doubtful	1.5-2	Recommended
Adequate	2-3	No
Good	3-4	No
Excellent	> 4	No

Sometimes in new or completely rewound machines, the 1 minute IR value is very high though PI may be less than 2. In such cases, it is recommended that if PI value is between 1.5 & 2, the machines can be commissioned and run on load. Generally in epoxy based insulation systems. IR value establishes after prolonged running of machines. PI shall improve and be more than 2 after prolonged runs.

Drying is also necessary when in spite of adequate polarization index and 'insulation resistance value moisture is visible on the winding.

3.4 Drying Out Procedure

Extreme dampness will cause reduction of insulation resistance. New machine which have been standing idle for few weeks or more may need drying out. Particularly if they have been subjected to wide and rapid temperature changes or have been in wet or humid surroundings. For ex. Setting concrete quite often results in extreme humidity.

The time required for drying out depends upon the initial degree of dampness and may extend from one day to several days. Out of several drying out processes which ever process is selected, it is essential that the heating process is continuous and that the temperature is maintained constant at a value sufficiently high to ensure drying out but not so high that the insulation is damaged. A suitable temperature for drying out is 60 deg C to 70 deg C measured by using built in slot resistance thermometers. The temperature of the windings must not be raised faster than a few degree per hour (say max. 10 deg C) in order to prevent damage from differential thermal expansion. It will generally be found that at first as the temperature of the winding increases, the insulation resistance decreases until a minimum value is reached. This is due to a redistribution of the moisture in the winding and the drooping temperature resistance characteristics of the insulation.

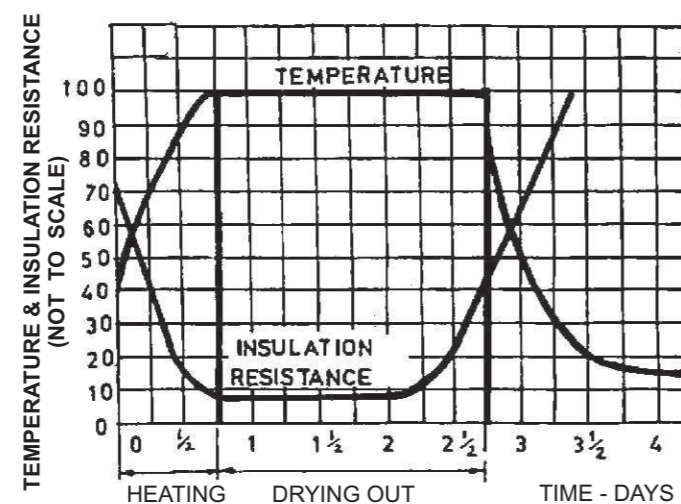

It is for these reasons that it is essential to maintain a constant temperature during the plotting of drying out curves a few degrees fall in temperature may give a misleading rise in the value of the insulation resistance.

If the temperature is allowed to fall considerably, re-absorption of moisture will take place. After a lengthy period during which the insulation resistance will remain practically constant at the minimum value. It will commence to rise

steadily until a maximum value is reached indicating that the machine is practically dry and ready for service.

A typical curve showing variation of insulation resistance with respect to temperature and time (when in the operation of drying out) clearly shows how the insulation resistance first decreases for initial heating and becomes minimum and remain for along time till it further increases to a maximum value after lapse of certain time (refer sketch).

During operation also the insulation resistance of the winding may decrease as a result of environmental and operating conditions. The critical value of the insulation resistance at a winding temperature of 25 degree C can be calculated depending on the rated voltage as mentioned earlier in this article.

If the measured insulation resistance value is above the calculated critical figure during operation, the machine can still operate further. However the winding must be dried if the IR value falls below the specified values. For the machines in operation the IR value should usually be checked after appropriate short intervals.

3.5 DRYING METHODS

For the purpose of drying winding, heat can be applied in three ways:

- By producing heat losses in the machine itself i.e. by operating the machine on short circuit.
Avoid temperature variations during the drying process. With totally enclosed machines, provision should be made (by removing covers etc) to permit the moisture to escape and for clean and dry air to enter. Where a drain plug is provided for water condensation on the underside of the motor, the same should be opened.
- By feeding current from external energy sources to produce heat losses in the windings e.g. with the aid of welding sets or controllable high current rectifiers.
- By providing a flow of hot air after suitably covering with tarpaulins.

With all these methods some air circulation must naturally be provided to allow the moisture to escape. The magnitude of the current in the winding or the quantity of heat applied should be controlled so as to fulfill the requirement i.e. starting with low values and regulated according to temperature rise. Winding cable leads in terminal boxes should be cleaned with dry rags before drying.

OPERATION

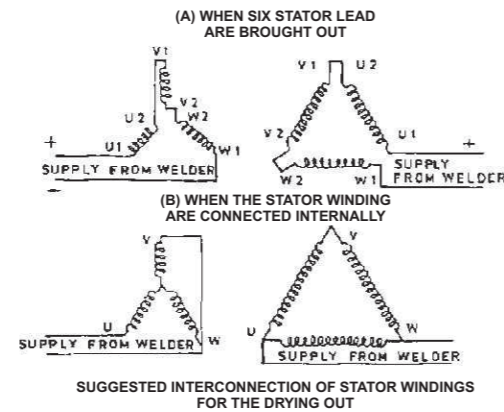

During short circuit drying rotor is blocked to avoid rotation. Apply a balanced three phase very low voltage (about 10% of normal stator voltage) supply across stator terminals. In the first 6 to 8 hours (depending on size of the machine) increase the stator current from about 0.5 times the rated current to a value such that the winding temp. Does not exceed 60 degree C. Monitor the progress of drying process by repeated measurement of insulation resistance and also observing the winding temperature.

If DC welding sets are to be used for drying machine windings certain precautions must be taken before connecting them. Because there is no ventilation, adjust the maximum permissible current for winding phase to 0.5 times the rated current. Connect the individual phases of the winding either in series or parallel. With series connection, connect the individual phases unsymmetrically (e.g. plus to U I. U2 to V1. V2 to W2. W 1 to minus) in order to keep axial magnetic flux in the shaft low.

Where the neutral point is not brought out, two phases must inevitably be paralld and connected in series to third phase (see sketch below). Change the connection order about every hour so that the winding is evenly heated. Measure the insulation resistance hourly. Before switching off a direct current the current should be gradually reduced to prevent winding inductance to cause arcing. Since the temp. distribution of the m/c at standstill is different from that in running condition, a winding temperature of 60 degree C should not be exceeded and rotor turned through 90 degree every hour. If methods 1 & 2 cannot be applied the machine must be dried with hot air obtained from an external source. The heaters can be arranged so that by means of suitable covers, the winding being heated is in hot air stream without concentrating the heat to the extent that excessive temperature is reached. This requires that the continuous circulation and replacement of the air takes place.



Commissioning, Operation and shutting down, Starting the machine, Operation, Shutting down.

Covers, which prevent accessibility to rotating and live parts -as well as those required for proper air guidance and effective cooling, must not be opened during operation.

COMMISSIONING INSTRUCTIONS

Instructions

The following instructions are a summary of the detailed information given in the supplementary instructions.

The following checks and tests should be performed after initial installation and subsequent inspection:

- Machine correctly aligned
- Drive elements correctly adjusted depending upon type (e.g. belt tension with belt drive, tooth flank and crest clearance with gear drives, radial and axial play with couplings, radial play, axial control and correct axial position with couplings of sleeve-bearing machines with two self-aligning bearings).
- Minimum insulation resistance of the windings satisfactory (also check after extended shutdowns)?
- Specified direction of rotation?
- Cooling air-flow not obstructed?
- Rotor revolves freely without touching?
- All fixing bolts, fastening devices and electrical connections tight?
- Earthing and potential-equalizing connections satisfactory?
- Bearing properly lubricated according to type and supplementary instructions?
- No bridging of any bearing insulation fitted
- Any auxiliary devices fitted properly connected and serviceable (e.g. temperature monitoring instruments in windings and bearings, anti condensation heaters, etc.).

- All protective measures against contact with moving or live parts properly implemented.

The following commissioning procedure is recommended after initial installation and subsequent overhauls:

- Starting the machine.
- Set the starter to the "start" position.
- Close the circuit-breaker and as soon as the machine starts moving open it again. If the machine does not start, do not move the starter to the next step but switch off and ascertain why it has not started. Rectify the fault.
- As the machine is coasting-down, listen and feel for any mechanical noise or vibration from the bearings and end shields.
- If the mechanical running of the machine is satisfactory switch on again and move the starter through its steps to maximum. Observe the machine briefly while it is running off-load (if the run is extended, start up the separate ventilation and cooling if applicable).
- If the machine runs roughly or there are any unusual noises, switch off and ascertain the causes during the coasting down.
- If the mechanical running of the machine improves immediately after switch-off it means that the causes are magnetic or electrical. If the running does not improve it means that the causes are mechanical, e.g. inadequate alignment of the set or unbalance in the machine, coupling or driven machine

Running :

- If the running is satisfactory start up any cooling system which may be fitted (separate fan, heat exchanger etc.) and load the machine. Check the running smoothness and take and record the readings of voltage, current, etc. As far as possible also take corresponding readings from the driven machine and record them.

Monitor and record the temperatures of the bearings, windings, etc. until the steady state is reached.

Temperature Setting :

Motor may be operated with temperature settings, as indicated by RTD, as tabulated below

		Permitted Max operating temp. (°C).	
Stator winding		125	
Bearing	Antifriction bearing	90	
	Sleeve bearing	BHEL design	80
		Renk design	93
Temperature setting (°C).			
	Initial	Final (based on stabilised operating data)	
Alarm	Permitted Max operating temp. +5°C	Recorded max operating temp. +5°C	
Trip	Permitted Max operating temp. +10°C	Recorded max operating temp. +10°C	

Shutting down :

- Open the circuit-breaker and return the starter to the "start" position. Allow the machine to coast down without braking.
- For motors with "Rank" bearings design, alarm and trip settings are +3°C and +7°C respectively instead of +5°C and +10°C settings



MAINTENANCE

Inspection Schedule

Careful maintenance and inspection allow any faults to be detected and corrected at any early stage before they are able to develop into serious damage. Therefore, they help to preserve the value of the machine, prevent costly outages and increase its reliability and availability.

Since the conditions under which the machines are required to operate can vary widely, it is only possible in maintenance and inspection schedules to recommend maximum intervals between inspections for normal conditions. Experience gained at the actual place of installation must be used subsequently to adjust the inspection intervals when necessary to take account of factors such as contamination, frequency of startup, load, etc. It is recommended, therefore, that the accessible parts of the machine are inspected visually about 500 hours after commissioning.

Furthermore, the inspection intervals given in the maintenance schedules presuppose no operating disturbances. If any disturbances or unusual operating conditions occur (e.g. over load, short-circuit, machine runaway, etc.) which cause electrical or mechanical overstressing of the machine, the appropriate inspections must be carried out immediately.

If BHEL engineers are not called upon to carry out the inspection work it should only be entrusted to trained personnel who have had adequate experience on large electrical machines.

We suggest that such personnel should be instructed by a BHEL engineer during his presence for installation, commissioning or inspections.

Repair work which goes beyond normal maintenance or inspection procedures, and any subsequent modification, etc. should always be carried out by BHEL engineers. Your local BHEL representative will be pleased to make the necessary arrangements.

The relevant safety and protection measures demanded by local regulations must be implemented when carrying out inspection and maintenance work.

The first inspection of machine should be made after 4000 operating hours or 1000 operations, but not later than 1 year (after 16000 operating hours in case of continuous operation, but not later than 2 years). Subsequent inspections

every 8000 operating hours (16000 operating hours in the case of continuous operation), but at least every two years.

The following checks should be carried out :

- Running smoothness of machine satisfactory.
- Rotor alignment within tolerances, also compare with initial reading.
- No cracks in the foundation.
- All fixing bolts of mechanical and electrical joints tight.
- Coupling, refer instructions of coupling manufacturer.
- Cleaniness of filters and coolers. Set intervals according to degree of contamination.
- Proper earthing of motor body and terminal boxes to be ensured.

Maintenance

Before starting any work on the machine, make sure that it has been isolated from the supply and that a safeguard has been provided to prevent unintentional starting.

Free Passages, which transfer cooling air from the ambient atmosphere, should be cleaned with dry, oil-free compressed air at regular intervals in accordance with the degree of pollution.

If dust or moisture has penetrated into the terminal compartment carefully clean and dry the component, in particular the surfaces of the insulating parts. Check the seals and eliminate the leakage.

Machines of vertical type of construction may be dismantled in a horizontal position. Refer to "Transport, storage" for the safety measures required to set down, lift and transport them. Before performing any work on the locating bearing with the machine in a vertical position, first brace the rotor.

ROLLING CONTACT BEARINGS

Instructions

Electrical machines fitted with rolling contact bearings (see Appendix) are subject to the following instructions supplementing and modifying the operation instructions of the machines.

Installation

The locating bearings are deep groove ball bearings for horizontally mounted machines. These bearings may also be in pair with cylindrical roller bearings. In the case of bearings in pair, the outer ring of the deep groove ball bearings is not guided radially and is prevented from rotating by compression springs.

The locating bearings for vertically mounted machines are angular contact ball bearings of type range 72 or 73 (angular contact ball bearings with increased axial fixation (see supplementary operating instructions)

The floating bearings are deep groove ball bearings or cylindrical roller bearings. In case of deep groove ball bearings as floating bearings, the axial play is compensated by means of compression springs.

The type of bearing is selected for direction and size of load (type of construction, forces acting on the shaft) and therefore it should not be changed. The permissible values of axial and radial forces may be taken from the list of machines or may be inquired.

The machines should operate in only one type of construction as shown in the rating plate, because another type of construction required perhaps further measures in addition to a modification of the model of bearing. Always in this case an inquiry is necessary.

The bearings should be re-lubricated (see "Maintenance") if the time between delivery and commissioning of the machines is more than 4 years, assuming that they have been stored in favourable conditions (i.e. in a dry, dust and vibration free room) or more than 2 years if they have been stored in unfavourable conditions.

Maintenance

For the initial lubrication of bearings, a lubricating grease IOC Servogem-3 or equivalent, with lithium soap as thickener and with mineral oil as basic oil as usually used.

Besides the definition of grease, the re-greasing interval and the necessary quantity are given on the data plate. Normally regular interval is 4000 hours.

It is recommended that the re-greasing instructions be followed strictly. Greases of different thickeners and basic oils reduces the quality and is therefore to be avoided. Only in special cases should deviations be made from the usual greasing, data. The re-greasing, intervals should be shortened, for instance, if the machines are operated at coolant temperatures higher than originally allowed for if corrosive vapours occur or extremely heavy contamination is present.

Clean the grease nipple and press in the grease stipulated on the data plate using a grease gun. At the same time shaft should be rotated in order to distribute the new grease uniformly in the bearing. After re-greasing, the bearing, temperature will rise by a few degrees and will drop to the normal value when the grease has reached its normal service viscosity and the excess grease has been forced out of the bearing.

The old grease from several re-greasing, operations gathers in the space inside the outer bearing caps. Remove the old grease when overhauling the machines.

For working on the locating bearing in the vertical position of the machine, support the rotor.

It is recommended that new rolling bearings be installed as follow: heat the ball bearings or the inner ring of the roller bearings in oil or air to a temperature of approx. 80 °C and slip them onto the shaft. Heavy blows may damages the bearings and must be avoided.

When installing single angular contact balls make sure that the broad shoulder of the inner ring (and the narrow shoulder of the outer ring) in operation position points upwards, i.e. in a direction opposite to that of the axial thrust.

Care must be taken during assembly to see that the sealing rings are fitted properly.

When fitting shaft seal rings (V-rings), the correct axial position or the V-rings is attained when the bearing cap end face and outside edge of the V-ring are flush. It is recommended using an appropriate assembly aid for this.

Before new felt sealing rings are fitted in to the bearing caps, they must first be impregnated in not so high viscosity oil (lubricating oil 51517-C100) at 80°C they should be dimensioned so that the shaft slides easily in, yet is also well enclosed by them.

The table given at Appendix-I helps to trace and remove the causes of faults.

It is difficult to find the damages of bearings. In the case of doubt it is recommended to renew the bearings.

BEARING ARRANGEMENT DE H-COMPACT Frame 31., 35., 40.

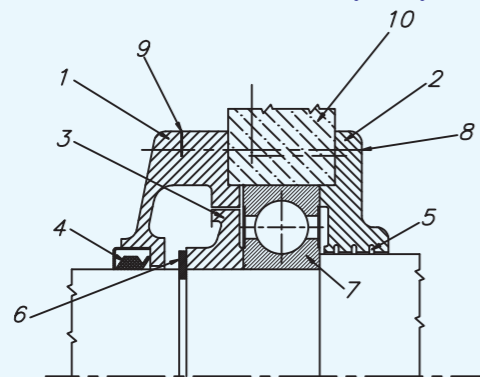

Sl. No.	ITEMS
01	Outer Brg. Cap
02	Inner Brg. Cap
03	Grease Flinger
04	Shaft Seal
05	Felt Seal
06	Circlip
07	Bearing
08	HEX Bolt
09	Grease Nipple
10	END-Shield

BEARING ARRANGEMENT NDE H-COMPACT Frame 31., 35., 40.

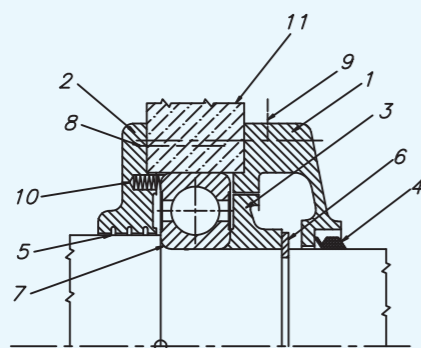

Sl. No.	ITEMS
01	Outer Brg. Cap
02	Inner Brg. Cap
03	Grease Flinger
04	Shaft Seal
05	Felt Seal
06	Circlip
07	Ball Bearing
08	HEX Bolt
09	Grease Nipple
10	Spring
11	END-Shield

HORIZONTAL BEARING ASSEMBLY H-COMPACT Frame 45., 50., 56.

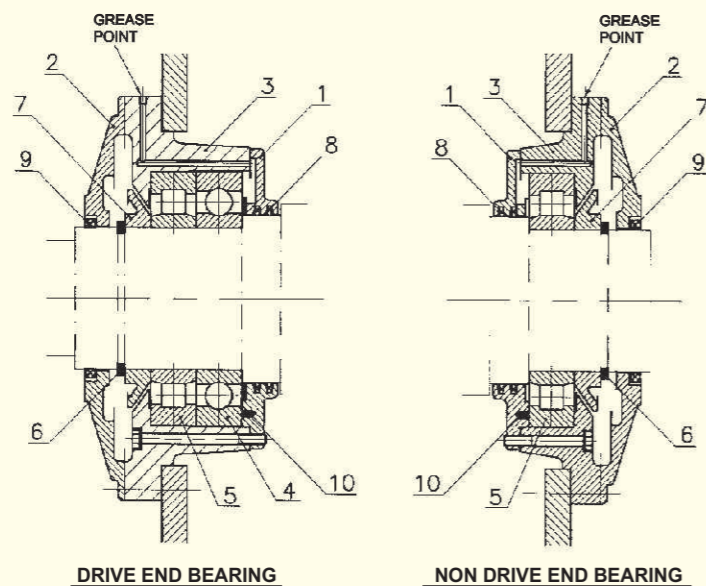

1.	INNER BEARING CAP
2.	OUTER BEARING CAP
3.	BEARING HOUSING
4.	BALL BEARING
5.	ROLLER BEARING
6.	CIRCLIP
7.	GREASE FLINGER
8.	FELT SEAL
9.	SHAFT SEAL
10.	SPRING

SLEEVE BEARINGS (BHEL DESIGN)

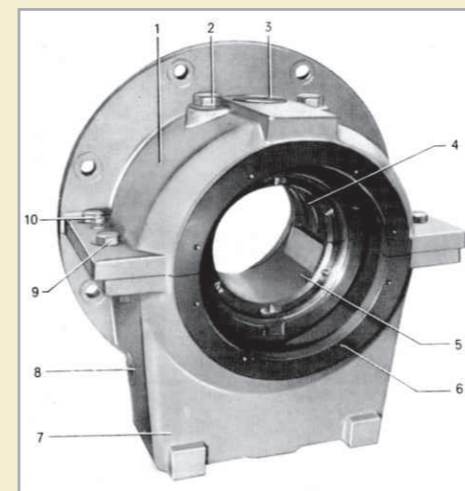

- | | |
|--|-------------------------------|
| 1. Bearing cover | 10. Tapper pin |
| 2. Oil filling plug | 11. Hole for fixing bolt |
| 3. Sight glass | 12. Centering ring |
| 4. Top bearing shell | 13. Oil drain screw |
| 5. Bottom bearing shell | 14. Thermometer well |
| 6. Tapped hole for insert sealing ring | 15. Oil-ring |
| 7. Bearing housing | 16. Inner insert sealing ring |
| 8. Sight glass | 17. Sealing cover |
| 9. Joint bolt | 18. Outer insert sealing ring |

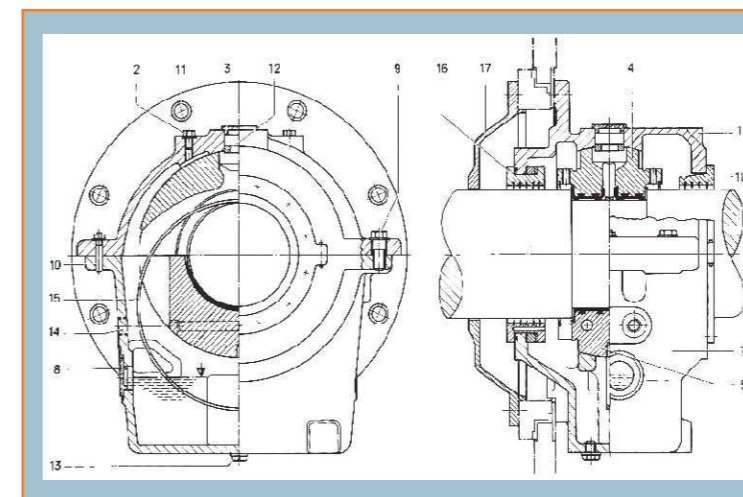

VERTICAL BEARING ASSEMBLY

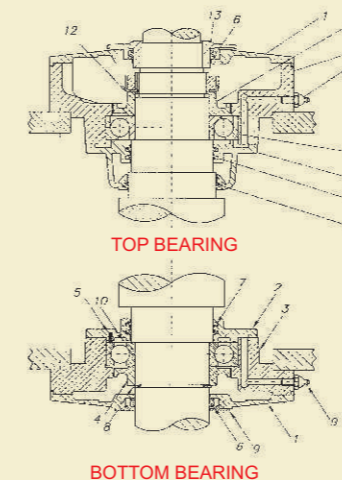

- | |
|------------------------------|
| 1. OUTER BEARING CAP |
| 2. INNER BEARING CAP |
| 3. BEARING HOUSING |
| 4. FLINGER |
| 5. SPRING |
| 6. SHAFT SEAL |
| 7. FELT SEAL |
| 8. CIRCLIP |
| 9. GREASE NIPPLE |
| 10. DEEP GROOVE BALL BEARING |
| 11. ANGULAR CONTACT BEARING |
| 12. LOCKING RING/NUT |
| 13. DUST SEAL |

CAUSED OF FAULTS AND REMEDY FOR BEARING				
CAUSES	DEFECT			REMEDY
	BEARING OVERHEAT	BEARING SCRATCHES	BEARING KNOCKS	
FELT SEALING RING PRESSING ON SHAFT			FIT RING INTO GROOVES OR REPLACE THEM
STRAIN APPLIED FROM COUPLING			IMPROVE ALIGNMENT OF MACHINE
EXCESSIVE BELT TENSION			REDUCE BELT TENSION
BEARING CONTAMINATED			CLEAN OR RENEW BEARING, INSPECT SEAL
AMBIENT TEMPERATURE HIGHER THAN 40 C			USE SPECIAL HIGH TEMPERATURE GREASE
LUBRICANT INSUFFICIENT		LUBRICATE TO INSTRUCTION
BEARING CANTED		CHECK MOUNTING CONDITION INSTALL OUTER RING WITH LIGHTER FIT
TOO LITTLE BEARING PLAY		FIT BEARING WITH LARGER PLAY
BEARING CORRODED		RENEW BEARING INSPECT SEALS
SCRATCHES ON RACEWAYS			RENEW BEARING
SCORING			RENEW BEARING, AVOID VIBRATION WHILE AT STAND STILL
EXCESSIVE BEARING PLAY			INSTALL BEARING WITH SMALLER PLAY

SLEEVE BEARINGS WITHOUT AXIAL LOCATION

Bearing Maintenance includes

- Inspecting the parts subject to wear (bearing liner, oiling, sealing rings)
- Checking bearing insulation.
- Checking the oil.
- Checking lubricating system for proper functioning and cooling.
- Checking bearing temperature.
- Oil change interval : Refer instruction plate on the bearings.
 - a) For self ring lubricated bearings - 4000 hours.
 - b) For bearings with external oil supply - 20000 hours.



DISMANTLING AND RE-ASSEMBLY PROCEDURE

6.1 GENERAL

Before dismantling the motor, ensure the availability of crane facility of adequate capacity, sufficient space and tools-tackles. For the purpose of de-threading the rotor, a mild steel pipe of minimum 10 mm wall thickness, ID suiting to accommodate motor shaft extension and length approximately equal to stator frame length, should be available. All loose fitments, accessories like RTDs, BTDs, dial type thermometers, space heater power supply connections, cooler blower motor power supply connections, oil inlet/outlet pipe connections and the cable terminations are to be removed / disconnected before dismantling the machine.

Removing the coupling half at drive end side is left to the choice of site engineer*. Since the fan is at drive end, this end can be slinged and the dethreading pipe can be inserted at NDE side after carefully protecting both the shaft journals. Refer the longitudinal sectional arrangement of the machine in sub-section 10 and the bearing assembly sketches in sub-section 5, study them carefully before attempting the dismantling of motor or bearing assembly.

*In case of motors with anti-friction bearings, DE bearing, end shield, fan and air guide baffle can be removed only if the coupling half is removed.

6.2 SEQUENCE OF DISMANTLING

Bearing assembly dismantling for oil lubricated sleeve bearing:

1. Drain off oil from the sump of bearing housing bottom at DE and NDE. In case of forced oil lubrication system disconnect oil inlet and outlet flanges.
2. The bearing assembly consists of top and bottom half bearing housing and top and bottom bearing half shells (liners).
3. Remove all accessories like BTD and vibration monitoring probes etc.
4. Before dismantling, proper match marking to be ensured between mechanical separable parts.
5. Remove top half bearing housing and preserve the loose spacer labyrinth half rings.

6. Preserve all the dowel pins carefully in their own respective assembly parts.
7. Remove top bearing sleeve top half.
8. Remove bottom half bearing sleeve after sliding it to top side. For this it is necessary to centrally lift the rotor slightly by using soft slings. Gently lower the rotor. Do not drop rotor abruptly. Preserve oil pick-up brass rings carefully. Remove it by splitting if it is in two halves.
9. Remove the bottom bearing housing, if required.
10. Remove end shields through jacking holes by suitably supporting them through a sling.

Bearing assembly dismantling for grease lubricated antifriction bearings:

1. Remove all fasteners and take out outer bearing cap (OBC).
2. Unscrew Inner Bearing Cap fasteners.
3. Carefully heat up grease flinger with a thin flame and remove by inserting studs in two threaded holes or by hands after wearing heat-resistant gloves.
4. Remove bearing housing through its jacking holes after carefully supporting the shaft by a soft nylon sling.
5. Unscrew end shield bolts and remove the end shield by jacking.
6. Remove shrink fitted bearings with help of suitable hydraulic/mechanical puller.
7. Remove inner bearing cap (IBC) by unscrewing its four long bolts.

6.3 DISMANTLING OF OTHER PARTS /ASSEMBLIES

- After dismantling of both side bearings , sling the rotor at both ends with almost equal air gap on all sides i.e. parallel to stator bore.
- Remove internal fan & air guide if required.
- Now the rotor can be de-threaded by use of extension pipe suitably either on DE or NDE. Utmost care must be taken that the stator end winding does not come into physical contact with rotor due to movement of rotor in slung position. De-threaded rotor should preferably be kept on wooden logs or soft padded V- blocks.

- If required, rotor can be de-threaded partially or fully from DE side by dismantling only NDE bearing and its assembly components. In this case end shield of DE will be required to be unscrewed and jacked out from its spigot. In this case, it is not necessary to dismantle NDE side antifriction bearing fully. Dismantling of NDE end-shield and bearing housing along with OBC will be sufficient.
- Protect the shaft journal face by enveloping the same with clean rag wool cloth all around and tying with rope.
- Do not disturb / remove any of the balancing weights on radial internal blower or on the balancing ring.

6.4 REASSEMBLY

Re-assembly of the motor is generally in reverse of the above respective procedure.

Motor with anti-friction bearings :

Clean and insert inner bearing cap (IBC) beyond bearing resting shoulder on shaft. Apply fresh grease on face of IBC to fill grease cavities.

Place all springs in blind holes of IBC & retain them in position by grease. (springs will rest on mean dia of outer race.)

At the same time, ball bearing and roller brg inner-race to be heated to around 100° to 120°C by induction heating or in a clean oil bath. Now shrink ball brg and inner-race of roller brg square to shaft. Apply fresh grease on accessible face of ball bearing.

Roller bearing cage assy filled with grease can be separately pressed in the housing.

Insert housing on to shaft. Align the IBC holes with holes of housing by suitably supporting the shaft by a soft sling keeping grease in-let hole in bearing housing on top. Use of guide ring avoids marks on inner race & rollers. Start heating of grease flinger to about 100° to 120° C.

Now tighten the bearing housing by gradually tightening 4 to 6 bolts at equally opposite location for uniform insertion of housing. At the same time pull the IBC as near as possible and try to hold IBC with its specified longer bolts and tighten the complete bearing assy.

Now ensure that housing to end shield is fully tight and no gap is left between

faces. At this stage the rotor should be free to rotate if NDE bearing is also assembled.

Inject grease to check grease path. Shrink grease flinger on to shaft. Insert circlip in groove provided on shaft.

Ensure that circlip is fully seated in groove & there is no gap between flinger & circlip. Unscrew all fixing bolts between bearing housing to end shield and insert outer bearing cap (OBC). Now align the holes of OBC with hole of brg housing and end shield and tighten all three items together.

Assemble the NDE bearing in same order. Springs and ball bearing are to be omitted in NDE bearing assembly.

Motor with oil-lubricated sleeve bearings :

During re-assembly ensure that the metal to metal joints between bearing housing and end shields and stator frame terminal box flanges faces and all inspection covers are applied with non-hardening jointing compound as a joint sealant to ensure Ingress Protection. The non-hardening jointing compound should not contain silicon. It is also recommended to use this sealing compound when inserting fastening bolts/screws.



FAULT DIAGNOSIS CHART

The chart lists general faults due to electrical and mechanical factors. Bearing faults are dealt with in the supplementary instructions for bearings.

FAULT, ELECTRICAL				POSSIBLE CAUSE	REMEDY
RUBBING NOISE	EXCESSIVE TEMPERATURE	RADIAL OSCILLATIONS	AXIAL OSCILLATION		
	•			AIR SUPPLY OBSTRUCTED, WRONG DIRECTION OF ROTATION	CHECK AIR PATH, CHANGE FAN
•				REVOLVING PARTS RUBBING	ASCERTAIN CAUSE, RE-ALIGN, RECTIFY
		•		ROTOR UNBALANCED	UNCOUPLE ROTOR AND REBALANCE
		•		UNBALANCED IN COUPLED MACHINE	REBALANCED COUPLED MACHINE
		•		ROTOR OUT OF TRUE, SHAFT DISTORTED	DISCUSS WITH FACTORY
		•	•	MISALIGNMENT	RE-ALIGN MACHINE, CHECK FOR MISALIGNMENT WHEN HOT, CHECK COUPLING
		•	•	INTERFERENCE FROM GEARING	CHECK GEARING
		•	•	RESONANCE FROM FOUNDATION	STIFFEN FOUNDATION AFTER CONSULTING FACTORY
		•	•	CHANGE IN FOUNDATION	ASCERTAIN CAUSE OF MACHINE AND ELIMINATE, RE-ALIGN MACHINE
			•	IMPULSES FROM COUPLED MACHINE	EXAMINE COUPLED MACHINE
	•			OVERLOAD	REDUCE LOAD

FAULT, ELECTRICAL									POSSIBLE CAUSE	REMEDY
Motor fails to start	Motor Accelerates reluctantly	Abrupt start up	Humming noise during start up	Humming noise during operation	Humming noise in rhythm of Double sliin frequency	Excessive temperature during no load running	Excessive temperature when running under load	Individual winding section overheat		
•	•			•			•		OVERLOAD	REDUCE LOADING
•									ONE SUPPLY OPEN CIRCUITED	CHECK SWITCHGEAR AND SUPPLY CIRCUIT
	•		•	•			•		ONE SUPPLY PHASE OPEN CIRCUITED AFTER SWITCHING ON	
•	•		•	•	•		•		OPEN CIRCUIT IN SECONDARY CIRCUIT	CHECK SWITCHGEAR SUPPLY CIRCUIT AND STARTER
	•								LOW SYSTEM VOLTAGE; HIGH FREQUENCY	CORRECT SYSTEM CONDITION
						•			LOW SYSTEM VOLTAGE; LOW FREQUENCY	
•	•		•	•				•	STATOR WINDING INCORRECTLY CONNECTED	CHECK WINDING CONNECTION
	•		•	•				•	INTER-TURN OR PHASE SHORT CIRCUIT IN STATOR WINDING	MEASURE WINDING RESISTANCE AND INSULATION RESISTANCE. REPAIR AFTER CONSULTING FACTORY
		•	•						INTER-TURN OR PHASE SHORT CIRCUIT IN ROTOR WINDING	
		•			•				STARTER INCORRECTLY CONNECTED	CHECK CONNECTION
		•							RESISTANCE OF FRIST STARTER STEP TOO LOW, FLAH OVER IN LIQUID STARTER	CHECK ELECTROLYTE COMPOSITION, INSULATION RESISTANCE OF STARTER ACCORDING TO THE INSTRUCTIONS

PRESERVATION MEASURES

For assembled but non-operative machines (without regular maintenance) and machines not commissioned for a long time after assembly).

Preservation

The machines which are not to be taken in operation are to be properly preserved for long duration. The purpose is to prevent condensation from forming in the machine, i.e. keep relative air humidity below 70% and, where necessary, make provision for heating and air circulation.

Possible measures

Pack machine moisture proof in sealed polyethylene folium. Place desiccant inside cover and month duration of application). Check desiccant and renew if necessary.

In less critical areas (e.g. storage in warehouses) switch on anti-condensation heating or blow a constant stream of warm air through the machine by means of fan heater. Apply a coat of anti-corrosion agent (e.g. Tectyl 506) to all bright surfaces outside the bearings.

If the rotor contains components (e.g. end bells) made of material subject to stress corrosion cracking (if necessary check with manufacturer), these must be protected properly as instructed by manufacturer.

In case of oil lubricated sleeve bearings , drain oil from bearings. Open sleeve bearings .Coat the bearing parts and journals of the shaft with anti-corrosion agent (e.g. Tectyl 506). Remove bearing shells for this purpose (uncouple the machine if necessary) and refit after coating. Close bearings.

Follow the manufacturer's recommendations concerning preservation of rolling contact bearings.

Rotors equipped with rolling contact bearings must be locked radially or axially to prevent the rotor from being damaged by vibration. Spare machines must be kept in a place not exposed to vibration.

Apply a coat of anti-corrosion agent (e.g.Tectyl 506) to all bright surface e.g. couplings.

Fill backstops with anti-corrosion oil (like Shell-Ensis 152).

Remove oil lines. If necessary, clean and coat inside with oil-soluble anti-corrosion agent (e.g. Tectyl 472). Carefully seal open pipe ends.

Clean cooler pipes and chambers. Fill clean cooler with mixture of water, anti-freeze and anti-corrosion agent. The composition of the mixture should be suited to the local climatic conditions.

Carefully remove all brushes from the brush boxes and secure them to their boxes with the pressure fingers.

Smear acid-free Vaseline like shell 8422, on steel slip ring contact surfaces and cover with polyethylene folium.

Keep a list of preservation measures that have been taken. The effectiveness of these measures should be checked by qualified staff at regular intervals. If any deterioration is noticed, remedy this immediately and remove any perceptible corrosion and other damage.

Reactivating

Commissioning of machine or restarting of a machine after a period of shutdown can only be taken up after the preservation agents have been removed. Restore the machine to its machine condition and make everything ready for commissioning. Before starting the machine, carry out all pertinent operations described in "Commissioning and shutting down".



SAFETY PRECAUTIONS

- 1.0 **When operating the motor**, the following basic safety precautions must be observed.
 - 1.1 No work shall be carried on running motor.
 - 1.2 In order to carry out any work on motor or driven unit, the motor must be disconnected from the mains and fool proof protection be provided to avoid any possibility of accidental switching on of the motor or of rotor revolving from the driven end side.
 - 1.3 Motor frame, main terminal box and sheath armour of the cable must be reliably earthed.
 - 1.4 Rotating parts such as driving end of the motor shaft or coupling must be provided with a trustworthy guard to protect the servicing personnel or people passing close by.
 - 1.5 If the feeding cables are to be disconnected from the motor, the cables ends must be short circuited.
 - 1.6 When working on high voltage starting equipment, all safety rules pertaining to high voltage installation should be observed.
- 2.0 **When handling the motor** or sub assemblies, it is necessary to take all the safety precautions, a few of which are listed below.
 - 2.1 All lifting equipment and attachments should be in good condition, tested and properly selected.
 - 2.2 Ascertain the weight of the load prior to lifting it and remove all loose items lying on it.
 - 2.3 When lifting the motor and other parts by the lifting bars, hooks of eye bolts, these should be carefully examined.
 - 2.4 Put padding of soft materials at places where the slings touch the stator frame.
 - 2.5 All manipulation should be done carefully without jerks.
- 3.0 **While handling the rotor**, the followings must be strictly observed.

- 3.1 Do not let the ropes touch the journal surface of the shaft.
- 3.2 While lifting the motor do not apply force to the parts of the shaft between the extreme ends up to the surfaces under, the bearings including journals.
- 3.3 Do not support the motor on rotor overhang and fans.
- 3.4 Do not support the motor on parts of the shaft between the extreme ends up to the surfaces under the bearing including journals.
- 3.5 Any equipment connected/coupled on the NDE- side the motor, provided with bearing insulation, must be thoroughly, insulated from machine/earth to prevent flow of shaft current in the motor.
- 3.6 In no case shall any part of rotor touch the winding overhang during insertion or removal of rotor from stator. It is desirable to cover the winding overhangs on both the ends by thick presspahn or leathroid or Elephantide paper as a protection.

NOTE : The safety precautions mentioned in the modules, should also be followed while attending to motor sub-assembly.



ENVIRONMENTAL GUIDE LINES

Environmental Guide Lines

SAFE DISPOSAL OF AC MACHINES ITEMS (After expiry of useful life)

BHEL has adopted an Environmental Policy and pledged to fulfill its responsibility of protecting and conserving the environment on account of its product.

Items/materials of AC machines, served their useful life are to be disposed off in an environment friendly way to protect our resources and control, environmental pollution. ("Guidelines furnished below lead to a long way in planning activity for scrapping the above effectively in an echo-friendly manner.

AC machines are basically manufactured by using the following :

01- Metals.

02- Non Metals

03- Lubricating oils.

These items should be disposed off/recycled/re-used as per current environmental laws of the Country.

METALS (Structural Steel, Copper, Aluminum etc.):

These may be sold as scrap metal for recycling and re-use.

NON METALS (Insulating Materials (Mica, Glass, Nomex, Epoxy/ Polyester/Silicone based bonding materials), Rubber (Synthetic/ Natural) Grease etc.):

Big pieces & useable lengths of insulating materials may be salvaged for re-using as insulation in smaller & lower voltage rating electrical equipment. Materials unfit for economic salvaging, should be stored in an isolated space for further safe disposal.

LUBRICATION OILS :

Oils should be recycled after cleaning and when become unserviceable, may be disposed off to refiners for lower end use as low-grade lubricating oil.



LIST OF RECOMMENDED SPARES

When ordering spare parts, please state the type and serial number of the machine as shown on the rating plate, data plate and at the Drive-end shaft face in addition to the exact designations of the parts required.

A - For all machines

Type of Machine	Assembly Name	Type	Items	Quantity	Style/ Drawing Number
SCIM 1LA4	Bearing (See 'B' for vertical motors)	Antifriction	Ball bearing - DE	One	
			Roller bearing - DE	One	
			Roller bearing - NDE	One	
			Outer Rubber Seals (DE and NDE)	One each	
			Inner Felt Seals (DE and NDE)	One each	
		Journal	Bearing bush - DE	One	
			Bearing bush - NDE	One	
			Sealing ring - DE and NDE	One set each	
			Oil ring - DE and NDE	One each	
		Line side Terminal box	Phase segregated box with direct termination	Connector	One set
	Joint box			One set	
	Desiccators			One set	
	Phase segregated terminal box with tail lead		Connector	One set	
			Insulator	One set	
			Tail lead	One set	
			Joint box	One set	
	Phase separated terminal box		Desiccators	One set	
			Connector	One set	
			Joint box	One set	
				Terminal bushing	One set
			Insulator	One set	

Type of Machine	Assembly Name	Type	Items	Quantity	Style/ Drawing Number
	Neutral side Terminal box	Neutral terminal box PSTB type	Neutral connector	One	
		NTB suitable for CT mounting used without CT	Bushing / Insulator	One set	
	Instruments	Bearing temperature detector-PT-100	Rigid stem type	One	
			Capillary type	One	
		Air temperature detector if provided	Rigid stem type	One	
			Capillary type	One	
		Space heaters	Plug in heaters	One set	
			Heaters for IL type motors	One set	
	Dial thermometer for bearing	Rigid stem type	One		
		Capillary type	One		

**B - Only for vertical motors
(in place of bearings as called in section A)**

Type of Machine	Assembly Name	Type	Items	Quantity	Style/ Drawing Number
Vertical Machine	Bearing	Antifriction	Top Angular Contact Ball bearing	One	
			Bottom Ball bearing	One	
			Outer Rubber seals (DE and NDE)	One each	
			Inner Felt seals (DE and NDE)	One each	



