

FIRST ANGLE PROJECTION

DRG. NO. 3-17505-40460

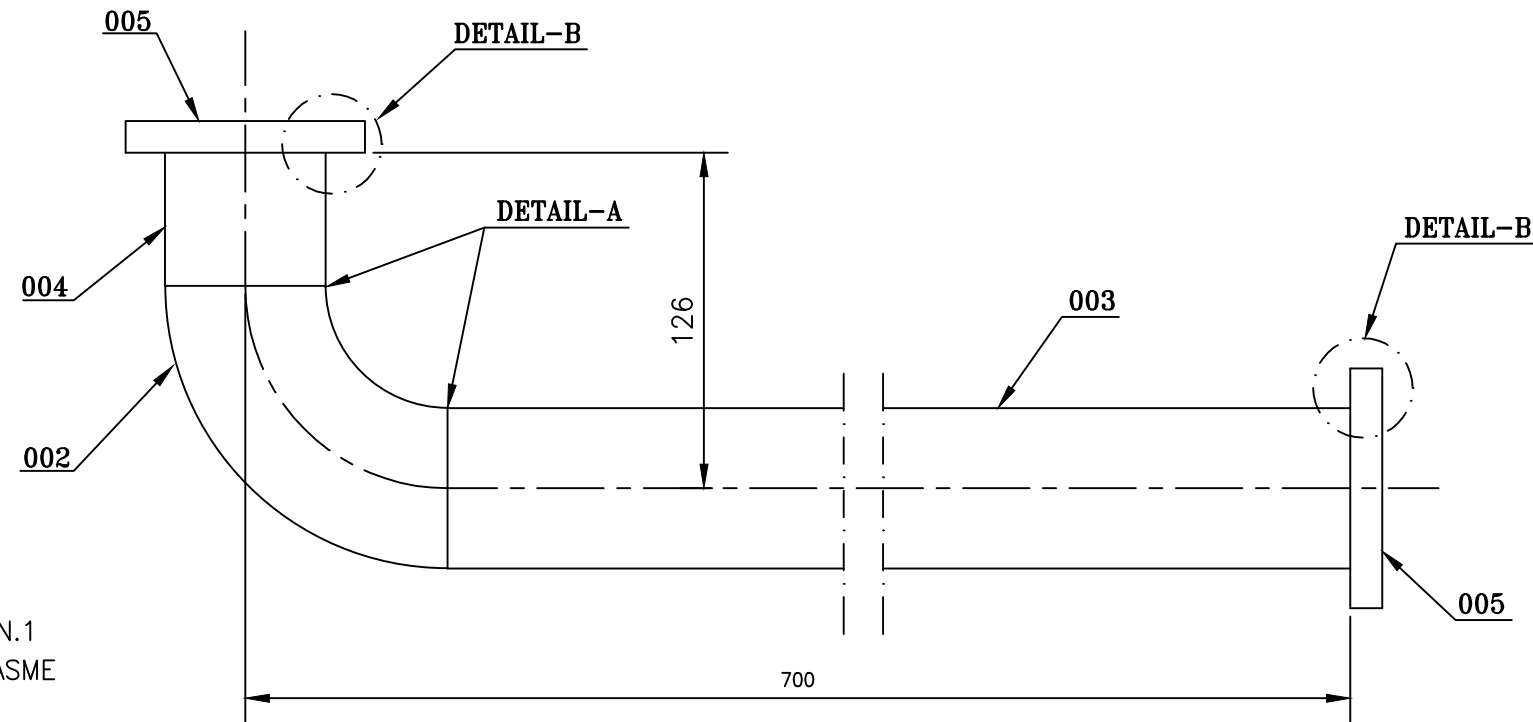
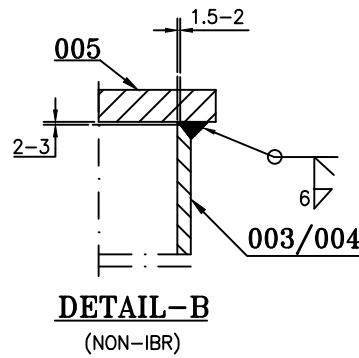
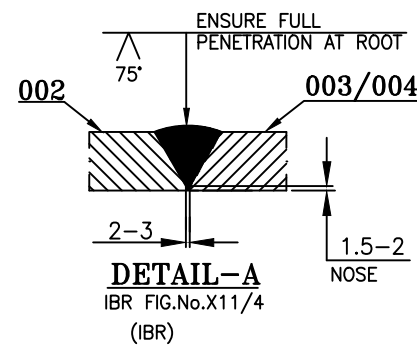

ASSLY.OF ITEM 001,VAR.00

TECHNICAL REQUIREMENTS(TR)

1. FABRICATION TO IN LINE WITH IBR-1950 CLASS 1.
2. FABRICATION TO BE DONE USING IBR QUALIFIED WELDERS ONLY.
3. ALL BUTT WELDS & CORNOR WELDS TO BE CHECKED BY DYE PENETRATION EXAMINATION AS PER APPEDIX-8 OF ASME SEC.VIII DIVN.1
4. ALL BUTT WELDS TO BE FULLY RADIOGRAPHED AS PER UW-51 OF ASME ASME SEC.VIII DIVN.1;2004.
5. DRILL & TAP HOLES IN BLANK (ITEM 005) AS REQUIRED IN SHOP, FOR HYDROSTATIC TESTING OF ASSY.
6. FABRICATION ASSY. TO BE CLEANED BY SHOT BLASTING TO Sa 2 1/2 FINISH AS PER SIS-055900.
7. FABRICATION ASSY. TO BE CHECKED BY HYDROSTATIC TESTING FOR 30 MINUTES, MINIMUM.
8. PAINTING AFTER SHOT BLASTING
  - 8.1 INSIDE SURFACE: NIL
  - 8.2 OUTSIDE SURFACE: TWO COATS OF HEAT RESISTANT AIR DRYING ALUMINUM PAINT AS PER AA-56134

QTY.	ITEM NO.	DESCRIPTION	UNIT	WT.	ZONE
02	005	BLANK-50NB 12TK.	KG	060	
01	004	PIPE-50NB 60.3 ODx8.74TK.	MR	0.56	
01	003	PIPE-50NB 60.3 ODx8.74TK.	MR	6.93	
01	002	ELBOW - LR 50NB SCH.160	NO	2.65	
1	001	CONNECTING PIPE ASSLY.	NO	11.40	

DESIGN DATA	
DESIGN PRESSURE	50.0 Kg/cm <sup>2</sup> g
DESIGN TEMP.	285°C
HYDROSTATIC TEST PRESSURE	75.0 Kg/cm <sup>2</sup> g

ISSUED BY \_\_\_\_\_ CHECKED BY \_\_\_\_\_ APPROVED BY \_\_\_\_\_

**I.B.R.**  
 ADDITIONAL INFORMATION  
 DRG. LIST No.4-17500-40040  
 STATUS OF DRAWING  
 DISTRIBUTION OF PRINTS  
 CDE-1 HCM-4

**H.P.HEATERS STANDARD**  
 भारत हेवी इलेक्ट्रिकल्स लिमिटेड भोपाल  
**BHARAT HEAVY ELECTRICALS LTD. BHOPAL**  
 नाम / NAME: NEETU ARYA  
 हस्ता / SIGN.:  
 दि. / DATE: 23.02.07  
 चे. की संख्या / NO. OF VAR.: 001

REV.	DATE	ALTERED THAWANI
01	20.02.08	CHECKED SAXENA S. APPROVED TAURANI M.L.
ZONE		DESIGN TEMP. ADDED.

भाग / DEPT. CODE: 411  
 उन्तोल. दिस. ग. / UNTOL. DIMS. GR.: M  
 कोड / CODE: AA 0230208  
 भा. कि.ग. / WEIGHT(K.G.): 11.40  
 उतुपत / SCALE: 1:2.5

उत्पाद का प्रकार या गृहक / परिचयना का नाम  
 TYPE OF PRODUCT OR NAME OF CUSTOMER/PROJECT  
 उतुपत / SCALE: 1:2.5  
 भा. कि.ग. / WEIGHT(K.G.): 11.40  
 उतु. ड्राईंग का संदर्भ / REF. TO ASSY. DRG.:  
 मद्र. क. / ITEM NO.: 006  
 मद्र. संख्या / NO. OF ITEM: 005  
 ड्राईंग क. / DRAWING NO.: 3-17505-40460  
 पृष्ठ क. / SHT. NO.: 1 पृष्ठों की सं. / NO. OF SHT.: 1

THE INFORMATION ON THIS DOCUMENT IS THE PROPERTY OF BHARAT HEAVY ELECTRICALS LIMITED IT MUST NOT BE USED DIRECTLY OR INDIRECTLY IN THE WAY DETRIMENTAL TO THE INTEREST OF THE COMPANY.

REF. DRG. NO.

SIGN. & DATE

INVENTORY NO.