

FIRST ANGLE PROJECTION

(ALL DIMENSIONS ARE IN mm)

35217001774 DRG. NO.

TOOL LIST	
1564013	WELDING FIXTURE
1564014	CHECKING FIXTURE

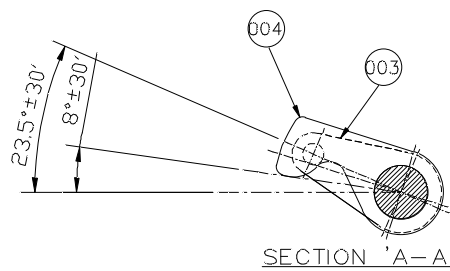
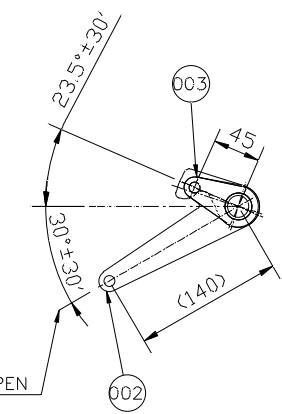
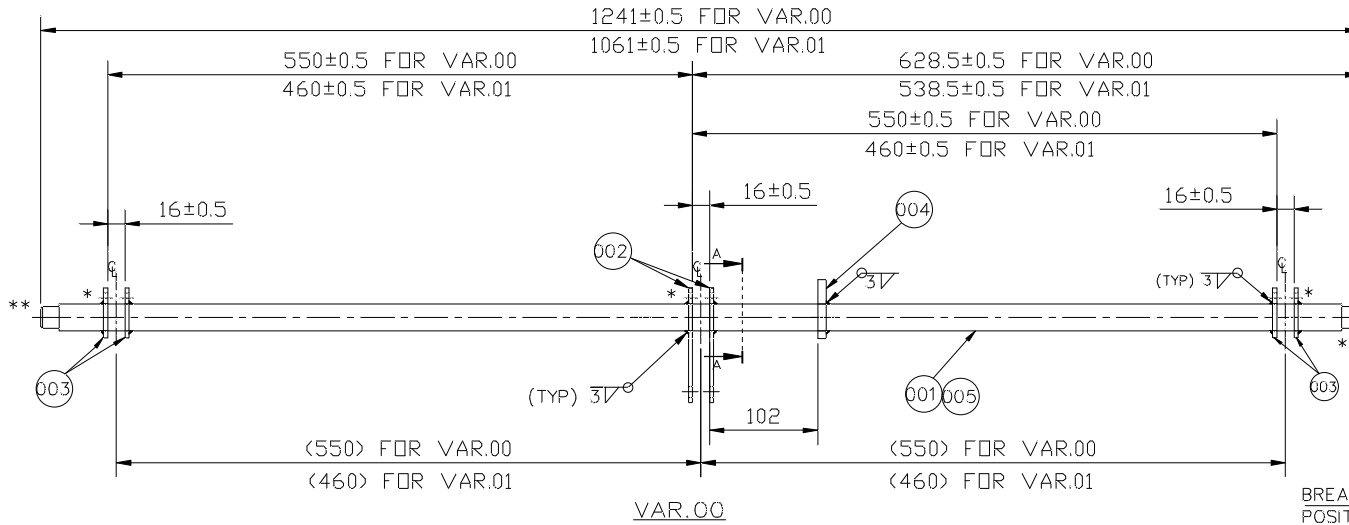

REV.	DATE	ALTERED CHECKED APPROVED	REV.	DATE	ALTERED CHECKED APPROVED	ITEM NO.	DESCRIPTION	STD.	DRAWING NO.	IT.NO	MATL. CODE	UNIT	UNIT WT.	QTY.	ZONE
			005			005	SHAFT		4 521 70 01513	002		KG.	4.00		
			004			004	DAMPING LEVER		4 521 30 30678	001		KG.	0.115		
			003			003	LEVER		4 521 70 01736	001		KG.	0.046		
			002			002	COMBINED LEVER		4 521 70 01735	001		KG.	0.225		
			001			001	SHAFT		4 521 70 01513			KG.	4.77		
VAR.01	VAR.00	REMARKS	VAR. NO.	ITEM NO.	DESCRIPTION	STD.	DRAWING NO.	IT.NO	MATL. CODE	UNIT	UNIT WT.	QTY.	ZONE		

BP9099472080 FOR VAR. 00  
BP9099472331 FOR VAR. 01

NOTE:-  
\* 1. THIS HOLES TO BE IN LINE WITH IN ±0.2mm THROUGH OUT, CHECK WITH SINGLE SS ROD Ø9.5<sup>+0.125</sup>/<sub>-0.000</sub>  
2. WELDING SEQUENCE TO BE FOLLOWED TO AVOID DISTORTION.  
3. USE WELDING FIXTURE.  
4. WELD SHALL BE TO GRADE 3 AS PER AA 0622101.  
\* 5. THIS AREA SHALL NOT BE PLATED.

FINISH:-  
ZINC PLATED AND PASSIVATED TO AA 0673603 AND AA 0673604 (0.005 TK. MIN.)

ADDITIONAL INFORMATION		
STATUS OF DRAWING		
DISTRIBUTION OF PRINTS		
□/C	SWM	TCX
1	3	1

mRikn dk i-dkj;k xk-gd@ffj;kstuk dk uke TYPE OF PRODUCT OR NAME OF CUSTOMER/PROJECT		PVN-12A	
HAKjr gsoh bysfDV&dYl fyfeVsl HAKsiky BHARAT HEAVY ELECTRICALS LTD. BHOPAL	DRN	uke@NAME	qlrk@SIGN
	tWpk CKD	S.R.	fnaukd@ATE
	vugqskshv APPD	N.B.	07.10.02
fchAK SWE DEPT vU_ Vky_ uki dh Js.kh UNTOL DIMS GR M dksM 409 CODE AA0230208	vugqkr SCALE 1:1	HAKj fd_xk- WEIGHT (KG) 6.3	vis_ M&kbZax dk lanHAZ REF. TO ASSY. DRG. en d- ITEM NO.
'kh'AZ@OLE SHAFT ASSY. (CENTERED) (12 KV PORCELAIN CLAD V.C.B.)		vksj[A d-@DRAWING NO. 35217001774	
i="B d-@No. 01		i="Bkso dh lo[:.NO. OF SHT.01	

INVENTORY NO. SIGN. & DATE REF. DRG. NO. 52170\35217001774-R00-S01