

THE INFORMATION ON THIS DOCUMENT IS THE PROPERTY OF BHARAT HEAVY ELECTRICALS LIMITED. IT MUST NOT BE USED DIRECTLY OR INDIRECTLY IN ANY WAY DETRIMENTAL TO THE INTEREST OF THE COMPANY.

5044658-R05-S01
REF.DRG.NO.

SIGN. & DATE

INVENTORY NO.

DRG NO 5044658

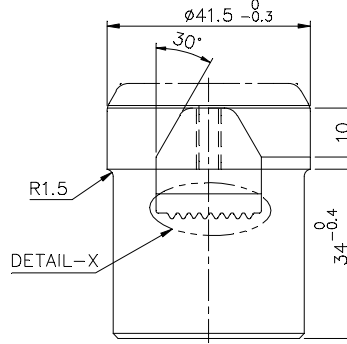
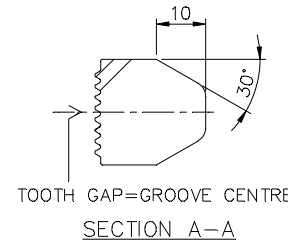
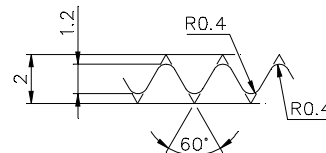
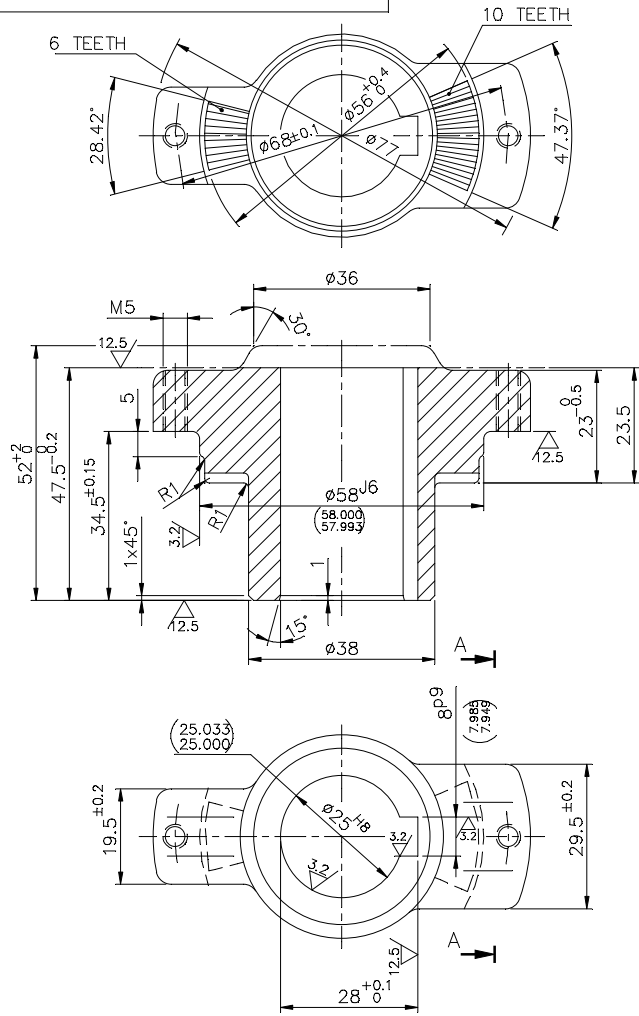

| TOOL LIST | | |
|-----------|----------|-------------------------|
| ITEM | TOOL NO. | DESCRIPTION |
| - | 1463871 | SOLTTING FIXTURE |
| - | 1463881 | DRILL JIG |
| - | 1520213 | KEY WAY BROACH 8 P9 |
| - | 1520342 | BROACHING FIXTURE |
| - | 1520346 | BROACHING ADAPTER PLATE |

Z = 76 TEETH IN 360° TOOTH PROFILE ON 56 DIA.

RADIUS NOT SHOWN =R3

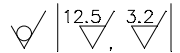

| | | | | | | | | | | | |
|--------|---------|---------|----------|--|-----|-------------|--------|---------------|---|------|----------|
| VAR 00 | REMARKS | VAR NO. | ITEM NO. | DESCRIPTION | STD | DRAWING NO. | IT.ND. | MATERIAL CODE | A | UNIT | UNIT WT. |
| | | | | 1.5% NI-CR-Mo PRECISION STEEL CASTING HEAT-TREATED | | | | BP 19594 | | KG. | 0.346 |
| | | | | | | | VAR | MATL. SPCN. | C | | QTY |
| | | | | | | | | | | | 001 |

| | | | | | | | | | | | | | | | |
|---|--|--|--|--------------------------------------|--|--|--|-----------------------------|--|--|--|---------------------|--|--|--|
| ADDITIONAL INFORMATION | | | | TYPE OF PRODUCT OR NAME OF CUST/PROJ | | | | | | | | | | | |
| STATUS OF DRAWING | | | | ON LOAD TAPCHANGER | | | | | | | | | | | |
| DISTRIBUTION OF PRINTS | | | | SWE | | | | SWM | | | | TCX | | | |
| 1 | | | | 3 | | | | 1 | | | | | | | |
| REV 06 | | | | DATE 11.07.11 | | | | ALTD CKD APPD | | | | VD KS SKP | | | |
| DRG. REDRAWN. DRG. WAS A4 SIZE. (D.C.A. NO. 21880) | | | | DEPT SWE CODE 409 | | | | UN. TOL.DIMGR. M AA 0230208 | | | | SCALE 1:1 | | | |
| | | | | TITLE | | | | COUPLING DOG | | | | REF TO ASSY 5014244 | | | |
| | | | | | | | | | | | | DRG NO 5044658 | | | |
| | | | | | | | | | | | | SHT.NO. 01 | | | |
| | | | | | | | | | | | | NO. OF SHT. 01 | | | |