

5049018 DRG. NO.

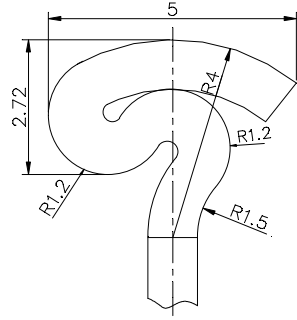

DETAIL-X  
(SCALE-10:1)

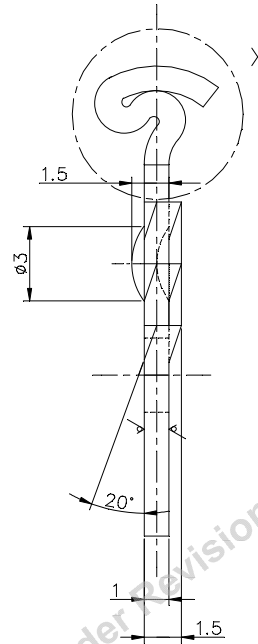

DEVELOPMENT LENGTH = 24 mm

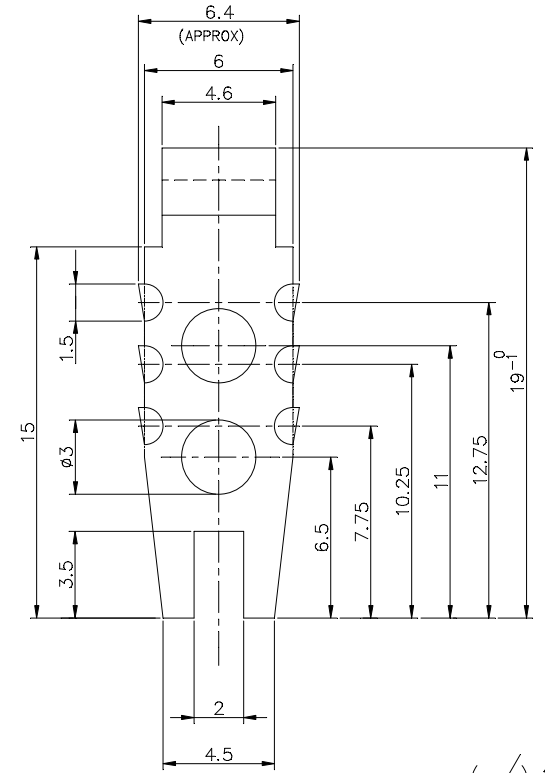

SILVER PLATED (0.010-0.015 TK.) AS PER AA 0673613  
SURFACE AREA = 2.59 cm<sup>2</sup>

(✓) 12.5/✓

THE INFORMATION ON THIS DOCUMENT IS THE PROPERTY OF BHARAT HEAVY ELECTRICALS LIMITED IT MUST NOT BE USED DIRECTLY OR INDIRECTLY IN ANY WAY DETRIMENTAL TO THE INTEREST OF THE COMPANY

5049018-R06-S01 REF. DRG. NO.

SIGN. & DATE

INVENTORY NO.

ACCEPTANCE CRITERIA

1. DIMENSIONAL CHECKING AND VISUAL INSPECTION FOR CRACKS.
2. ELECTRICAL CONDUCTIVITY.
3. SILVER PLATING THICKNESS.
4. SUPPLIER/ RAW MATERIAL MANUFACTURER TEST CERTIFICATE.

|                  |         |    |                  |          |                                      |    |    |    |                  |              |    |    |         |            |             |      |     |        |    |          |      |    |
|------------------|---------|----|------------------|----------|--------------------------------------|----|----|----|------------------|--------------|----|----|---------|------------|-------------|------|-----|--------|----|----------|------|----|
| 59               | 64      | 65 | 75               | 78       | 79                                   | 25 | 27 | 29 | 58               | 59           | 60 | 77 | 79      | 31         | 34          | 45   | 55  | 56     | 57 | 58       | 65   | 72 |
| VAR.OO           | REMARKS |    | VAR. NO.         | ITEM NO. | DESCRIPTION                          |    |    |    | STD.             | DRAWING NO.  |    |    | IT.NO.  | MATL. CODE | MATL. SPCN. | UNIT | KG. | 0.0005 |    | UNIT WT. | QTY. |    |
|                  |         |    | 001              |          | 1TK.x6.4x24 LG. HALF HARD BRASS SHT. |    |    |    |                  | AA1211902030 |    |    | AA12102 |            |             |      |     |        |    | 001      |      |    |
| 28 → CARD TYPE-3 |         |    | 28 → CARD TYPE-1 |          |                                      |    |    |    | 28 → CARD TYPE-2 |              |    |    |         |            |             |      |     |        |    |          |      |    |

ADDITIONAL INFORMATION

STATUS OF DRAWING

DISTRIBUTION OF PRINTS

|     |     |     |
|-----|-----|-----|
| SWE | SWM | TCX |
| 1   | 3   | 1   |

उत्पाद का प्रकार या ग्राहक/परियोजना का नाम  
TYPE OF PRODUCT OR NAME OF CUSTOMER/PROJECT

ON LOAD TAPCHANGER



भारत हेवी इलेक्ट्रिकल्स लिमिटेड  
भोपाल  
BHARAT HEAVY ELECTRICALS LTD.  
BHOPAL

| व्यवस्था DRN             | नाम/NAME | हस्ता/ SIGN | दिनांक/DATE | वै. की संख्या NO. OF VAR |
|--------------------------|----------|-------------|-------------|--------------------------|
| वै. का लोड अनुमोदित APPD | V.KUMAR  | Sd/-        | 02.01.77    |                          |
|                          | BSR      | Sd/-        | 04.01.77    |                          |
|                          | BSS      | Sd/-        | 05.01.77    |                          |

|      |          |                 |           |
|------|----------|-----------------|-----------|
| REV. | DATE     | ALTERED CHECKED | AKU KIRTI |
| 07   | 24.06.09 | APPROVED        | SKP       |

|            |                                       |              |                    |   |                      |
|------------|---------------------------------------|--------------|--------------------|---|----------------------|
| विकास DEPT | उत्प. रत. माप की श्रेणी UNTOLOMS. GR. | उत्पाद SCALE | भारत का भार (K.G.) | उत्प. इकाई का संदर्भ REF. TO ASSY. DRG. | भार. संख्या ITEM NO. |
| कोड 409    | MEDIUM AA023020B                      | 5:1, 10:1    | -                  | 5011482                                 | -                    |

DRG. REDRAWN.  
( DCA NO.-26689 )

|                       |                                  |          |
|-----------------------|----------------------------------|----------|
| विकास/TITLE           | उत्प. संख्या/DRAWING NO.         | पुन./REV |
| CONTACT               | 5049018                          | 07       |
| पृष्ठ सं./SHT. No. 01 | पृष्ठों की संख्या/NO. OF SHT. 01 |          |

FILE NAME: - KANSARA-5L47472