

THE INFORMATION ON THIS DOCUMENT IS THE PROPERTY OF BHARAT HEAVY ELECTRICALS LIMITED IT MUST NOT BE USED DIRECTLY OR INDIRECTLY IN ANY WAY DETRIMENTAL TO THE INTEREST OF THE COMPANY

FIRST ANGLE PROJECTION

(ALL DIMENSIONS ARE IN mm)

|      |      |          |      |          |         |             |
|------|------|----------|------|----------|---------|-------------|
| REV. | DATE | ALTERED  | REV. | DATE     | ALTERED | ADDITIONAL  |
|      |      | CHECKED  | 01   | 09.09.08 | AKU     | INFORMATION |
|      |      | APPROVED |      |          | KS      |             |
|      |      |          |      |          | SKP     |             |

DRG. REDRAWN.

(D.C.A. NO. 23434)

STATUS OF DRAWING

|                        |     |     |     |
|------------------------|-----|-----|-----|
| DISTRIBUTION OF PRINTS | SWE | SWM | TCX |
|                        | 1   | 3   | 1   |

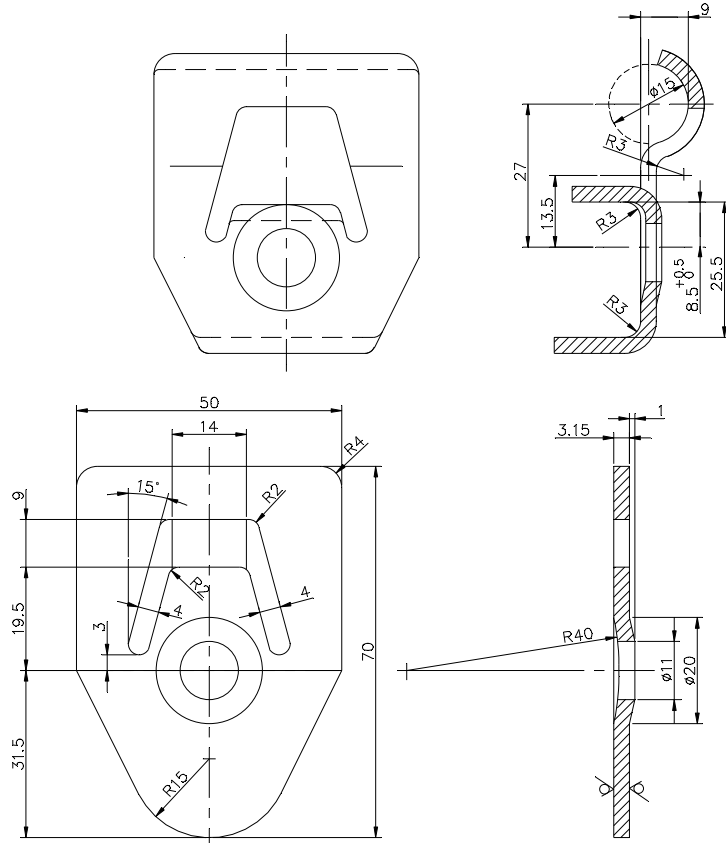

ZINC PLATE & PASSIVATE (0.015TK.) AS PER AA 0673603 & 0673604.

12.5 (∇)

|         |          |   |    |    |     |    |    |    |      |      |    |    |
|---------|----------|---|----|----|-----|----|----|----|------|------|----|----|
| 65      | 75       | 25                                      | 27 | 29 | 58  | 59 | 34 | 45 | 55   | 56   | 58 | 65 |
| REMARKS | ITEM NO. | DESCRIPTION                             |    |    | STD |    |    |    | UNIT | QTY. |    |    |
|         | 001      | 3.15 TK.x50x70 LG. C.R. CRBN. STL. SHT. |    |    |     |    |    |    | KG.  |      |    |    |
|         |          |   |    |    |     |    |    |    |      |      |    |    |

|    |             |   |             |  |                                  |
|----|-------------|---|-------------|--|----------------------------------|
| 28 | CARD TYPE-3 | 28  | CARD TYPE-1 | 28   | CARD TYPE-2                      |
|    |             | भारत हेवी इलेक्ट्रिकल्स लिमिटेड<br>भोपाल<br>BHARAT HEAVY ELECTRICALS LTD.<br>BHOPAL |             | नाम<br>DRN PVS<br>संस्था<br>Sd/-<br>दिनांक<br>03.01.77 | वे. रि. की संख्या<br>No. of VAR. |
|    |             |   |             | नाम<br>BSR<br>संस्था<br>Sd/-<br>दिनांक<br>08.01.77     |                                  |
|    |             |   |             | नाम<br>BSS<br>संस्था<br>Sd/-<br>दिनांक<br>08.01.77     |                                  |

|  |  |  |                        |                                    |   |                                  |                                 |
|--|--|--|------------------------|------------------------------------|---|----------------------------------|---------------------------------|
| विभाग<br>DEPT SWE<br>कोड<br>CODE 409           | उम. टोल. नाप की श्रेणी<br>UNTO. DIMS. GR.<br>M<br>AA 0230208 |  | अनुपात<br>SCALE<br>1:1 | भार कि.ग्रा.<br>WEIGHT (K.G.)<br>- | असेम्बली का संदर्भ<br>REF. TO ASSY. DRG.<br>5014478 | मद क्र.<br>ITEM NO.<br>-         | मद संख्या<br>NO. OF ITEM<br>001 |
| ड्राइंग/मॉडल<br>CLAMP<br>(ON LOAD TAP CHANGER) | ड्राइंग क्र./DRAWING NO.<br>5049803                          |  |                        |                                    | पृष्ठ क्र./SHT. No. 01                              | पृष्ठों की संख्या/NO. OF SHT. 01 | पुनः/REV.<br>01                 |

5049803-R00-S01  
REF. DRG. NO.

SIGN. & DATE

INVENTORY NO.