

Rev.	C.A.No.1852	Date	REV.	C.A.No.2275	Date
4	CKD. <i>18/06/83</i>	6.2.83	5	CKD. <i>18/03/98</i>	3.1.98
Drawing redrawn. Dim. ϕ 27.98/27.93 was ϕ 28f7 (27.98/27.95) Ab. added. & 14.63866 Grooving Tool 3,5 mm deleted. 27.98 Dim. ϕ 27.95/27.93 was ϕ 27.93.			Tools 1463082 Radius Tool R1,5 & 1520361 Bottom Die M22x1,5 added. & 14.63866 Grooving Tool 3,5 mm deleted. 27.98 Dim. ϕ 27.95/27.93 was ϕ 27.93.		
REV. C.A.No. 2383 DATE					
6 CKD. <i>18/06/83</i> 20/83					
Surface Area-65cm ² added.					

TOOL LIST		
ITEM	TOOL	DESCRIPTION
-	1463082	Radius Tool R1,5
-	1463083	Drill Jig
-	1463504	Palming Tool
-	1463861	Drill Jig
-	1520361	Bottom Die M22x15

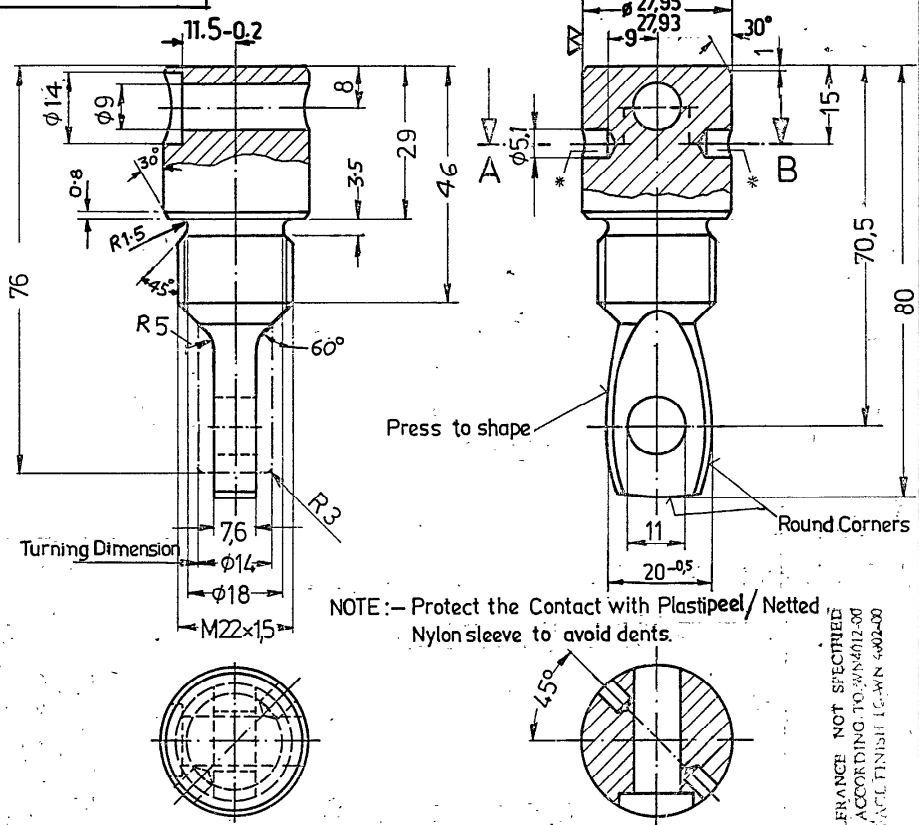

NOTE :- Protect the Contact with Plastipeel / Netted Nylon sleeve to avoid dents.

TOLERANCE NOT SPECIFIED ARE ACCORDING TO IS: 2874-00 SURFACE FINISH IS: 6.31-6.32-00

*) Hole in Section View (TURNED)

Hard Silver Plating : 10 to 15 μ m (150 - 180 HV) ∇ (W)
(Refer WN404:02 Sheet 5) Surface Area- 65cm²

32 Dia. x 76 Lg. Hard Copper Rod (AA12023) AA1200 223080

F	14368	11.284			
E	13141	13.78			
D	12362	21.676	TAPCHANGER D.O	Werkstoff:	Abmessung:
01	12221	32.76	CKD. Sd. MRM 3-3-77	E-CuF30 DIN40500	Rd 30 DIN 1756
C	11824	24.678	DRG Appd. BSR 7-2-77	Sach.-Nr	
B	11574	5.575	Desn. Appd. BSS 17-77	5110 029	
(A)	11689	213.75	Prints To:		
neu	11127	2911.74	SWE	1	
A I	And.-Nr.	Tag	Name	5	
				TCX (B). IV	1
Fur diese technische Unterlage behalten wir uns alle Rechte vor.			Scale		
			1:1		
			B.H.E.L BHOPAL		
			Star Point Contact Bolt		
			5055712:01/KS122		
			Ersatz f \ddot{u} h:	Ers. durch:	

- KTL
- KTE
- AVT
- AVV
- V
- VA
- KO
- MA
- MD
- MC
- D
- E
- 01
- 02
- 03
- 04
- 05
- 06
- 07
- 08
- 09