

FIRST ANGLE PROJECTION

(ALL DIMENSION ARE IN MM.)

THE INFORMATION ON THIS DOCUMENT IS THE PROPERTY OF BHARAT HEAVY ELECTRICALS LIMITED. IT MUST NOT BE USED DIRECTLY OR INDIRECTLY IN ANY WAY DETRIMENTAL TO THE INTEREST OF THE COMPANY.

|                        |      |          |                        |          |          |     |                        |     |
|------------------------|------|----------|------------------------|----------|----------|-----|------------------------|-----|
| REV.                   | DATE | ALTERED  | REV.                   | DATE     | ALTERED  | VD  | ADDITIONAL INFORMATION |     |
|                        |      | CHECKED  | 04                     | 15.11.13 | CHECKED  | KS  |                        |     |
|                        |      | APPROVED |                        |          | APPROVED | SKP |                        |     |
| DRAWING REDRAWN IN UG. |      |          | STATUS OF DRAWING      |          |          |     |                        |     |
| DCA NO. -52232         |      |          | DISTRIBUTION OF PRINTS |          |          | SWE | SWM                    | TCX |
|                        |      |          |                        |          |          | 1   | 3                      | 1   |

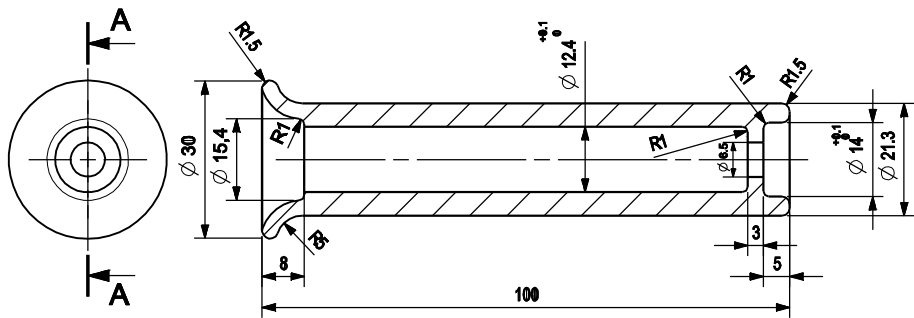

SECTION A-A

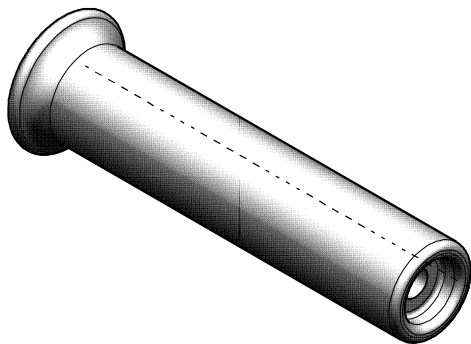

SIGN. AND DATE  
INVENTORY NO. 5560170-R02-501  
REF. DRG. NO.

|         |          |                |      |              |     |      |          |
|---------|----------|----------------|------|--------------|-----|------|----------|
| REMARKS | ITEM NO. | DESCRIPTION    | STD. | MATL. CODE   | A/C | UNIT | UNIT WT. |
|         |          | NYLON MOULDING |      | BP22962      |     | KG   | 001      |
|         |          |                |      | MATL. SPECN. |     |      | QTY.     |



BHARAT HEAVY ELECTRICALS LTD.  
BHOPAL

|                       |                   |       |               |                    |          |             |
|-----------------------|-------------------|-------|---------------|--------------------|----------|-------------|
| DPT. SWE              | UNTOL. DMS. GR. M | SCALE | WEIGHT (K.G.) | REF. TO ASSY. DRG. | ITEM NO. | NO. OF ITEM |
| CODE 409              | AA0230208         | 1:1   |               | 5011394            |          | 001         |
| TITLE                 |                   |       | DRAWING NO.   |                    | REV.     |             |
| HANDLE                |                   |       | 5560170       |                    | 04       |             |
| (ON LOAD TAP CHANGER) |                   |       | SHT NO. 01    | NO. OF SHT 01      |          |             |

|      |      |       |          |            |
|------|------|-------|----------|------------|
| DRN. | NAME | SIGN. | DATE     | NO. OF VAR |
| CKD. | VK   | SD/-  | 01.01.77 |            |
| APPD | BSR  | SD/-  | 04.01.77 |            |
|      | BSS  | SD/-  | 05.01.77 |            |