

THIS FACE TO BE
PARALLEL WITH BORE
FACES & AT 90° TO BORE

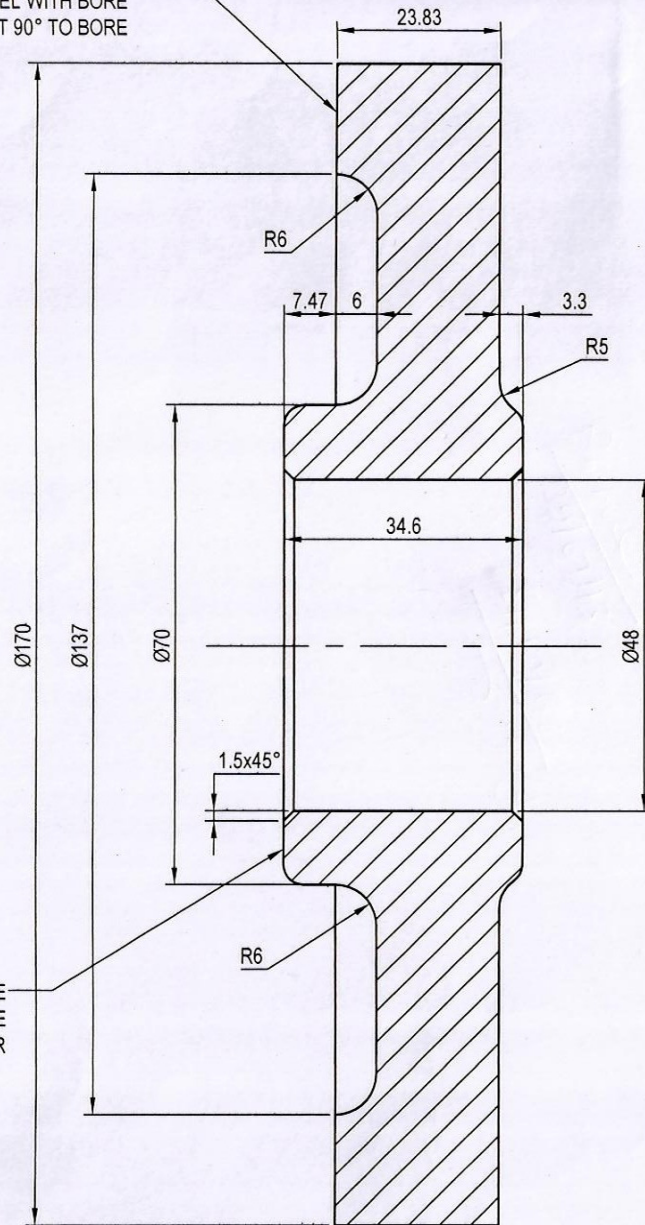

THIS FACE TO BE
SQUARE WITH BORE
WITHIN 0.025 TIR

NOTES:-

1. BORE TO BE PERFECT CONCENTRIC WITH OUTSIDE DIA. & PARALLEL TO WITHIN 0.0127.
2. ALL SHARP EDGES & CORNERS TO BE REMOVED.

GEAR BLANK (NYLON)	TME/00320	KG	-
DESCRIPTION	MATL. SPCN.	UNIT	QTY.

TITLE

GEAR BLANK (NYLON)

SKETCH NO.

TME/SKETCH/1003