

सामग्री सूची संख्या का

**AIR EXHAUSTER WITH MOTOR (RADIAL VENTILATOR)**

BASED ON BHEL'S OWN EXPERIENCE

SUPERSEDES INVENTORY NO. P-5718

**1.0 SCOPE :**

This specification covers the design, manufacture, performance requirements, testing and supply conditions of Air Exhauster with motor for sucking air steam mixture from gland steam condenser in a thermal power station.

**1.1 DESIGNATION :**

While raising purchase indent, mention the type (see Table-1, Page-9) and indicate quantity @ 2 nos. Per set, e.g. Air Exhauster with Motor - Type A to HE 57008.

**2.0 TECHNICAL DATA :**

**2.1 EXHAUSTER DATA :**

- 2.1.1 Medium to be handled : Air steam mixture
- 2.1.2 Suction temperature : See Table - 1.
- 2.1.3 Maximum Temperature : 350 °C
- 2.1.4 Total pressure : See Table - 1
- 2.1.5 Flow volume : See Table - 1
- 2.1.6 Density of air steam mixture : See Table - 1
- 2.1.7 Housing position : See Figure - 1

**2.2 MOTOR DATA:**

- 2.2.1 Rated output : To be indicated by the supplier.
- 2.2.2 Ambient Temperature : 50 °C
- 2.2.3 Supply : 415 Volts, 3Phase, 50C /s.
- 2.2.4 Type of enclosure : Totally enclosed fan cooled
- 2.2.5 Type of protection : IP 54 (IS:4691)
- 2.2.6 Mounting : As per figure 1
- 2.2.7 Starting : Direct on line
- 2.2.8 Voltage Variation : +/- 10%
- Frequency Variation : +/- 5%
- Combined voltage & frequency variation : +/- 10%
- 2.2.9 Insulation Class : B

स्वाधिकायक एवं गोपनीय  
इस प्रलेख में दी गई सूचना भारत हेवी इलेक्ट्रिकल्स की सम्पत्ति है इस्का प्रथम एवं अग्रस्थान रूप से किसी भी तरह प्रयोग, जो कि कंपनी के हित में

दिनांक एवं हस्ताक्षर  
SIGN & DATE

						नाम NAME	दिनांक एवं हस्ताक्षर SIGNATURE & DATE
TSX	B. CHOUDHARY	29.08.09	अनुवादक	TRANSLATED BY			
HXE	M.K. LAHOTI	19/8/09	निर्माणकर्ता	WORKED BY	ROHIT BANSAL		
QAX	S.K. CHAUHAN	29/8/09	जांचकर्ता	CHECKED BY	M.K. LAHOTI		
सहमत विभाग AGREED DEPTT.	नाम NAME	दिनांक एवं हस्ताक्षर DATE & SIGNATURE	पर्यवेक्षणकर्ता	SUPERVISED BY	L..KISHORE		

सामग्री सूची संख्या INVENTORY NO. P-5718

REV.NO.05	<b>(SUPERSEDES)</b>		स्वीकृति APPROVED L. KISHORE, AGM (HXE)				
Dt. 13.08.09			निर्माण PREPARED : HXE	जारी ISSUED : TSX			दिनांक 19/8/09 2-67



दिनांक एवं हस्ताक्षर SIGN & DATE		<b>उत्पाद मानक (हीप - हरिद्वार)</b> <b>PRODUCT STANDARD (HEEP - HARIDWAR)</b>	<b>HE 57008</b> पृष्ठ का Page 2 of 11
सामग्री सूची संख्या को SUPERSEDES INVENTORY	<p>2.3 GENERAL REQUIREMENT :</p> <p>2.3.1 The exhausters shall be supplied in pairs for each set , such that when two units ( per set) are installed with motor fan axis coinciding in one line (horizontal), one unit shall be a mirror image of the other. (Refer Figure - 2).</p> <p>2.3.2 Vibration of the equipment shall be limited to the maximum displacement of 50 microns. The measurement procedure shall be broadly as per IS: 12065.</p> <p>2.3.3 Noise level shall not be more than 85 dB at a distance of 1 meter. Noise level test shall carried out generally as per IS: 12075.</p> <p>2.3.4 Dynamic balancing of the impeller shall be done generally as per ISO: 1940 of the balance quality grade G6.3.</p> <p>2.3.5 The impeller shall be zinc sprayed. (Minimum thickness 60 micron).</p> <p>2.3.6 All the parts of the exhauster and motor shall be of corrosion resisting material or shall suitably and durably protected against corrosion.</p> <p>2.3.7 Suitable foundation on bolts (M16 x110) along with nut (M16), lock nut (M16) Spring washer 4 nos. (each) shall be supplied by the vendor for mounting of the equipment on foundation.</p> <p>2.3.8 Dimensional details shall be as per Figure -1</p> <p>2.3.9 Each fan exhauster shall be performance test at supplier's works as per IS: 4894.</p> <p>2.3.10 General arrangement drawing of the exhauster unit shall be got approved, before launching manufacture, in the event of placement of order.</p>		
COPYRIGHT AND CONFIDENTIAL The information on this documents is the property of Bharat Heavy Electrical Limited. It must not be used directly or indirectly in any way detrimental to the interest of the company	<p>3.0 DESIGN, MANUFACTURE &amp; WORKMANSHIP :</p> <p>3.1 The protective measure of exhauster shall be as per of IS 4894. In assembled condition, live parts shall not be accessible with the standard test finger (see IS: 401).</p> <p>3.2 The welding of the equipment shall be carried out by a qualified welder as per ASME Sec-IX.</p> <p>3.3 The motor shall have delta type stator winding connection.</p> <p>3.4 Minimum voltage required under starting up conditions to bring exhauster up to rated speed shall be 85% of rated voltage.</p> <p>3.5 Before undertaking manufacture, the vendor shall get its detailed drawing approved by BHEL, which shall include detailed dimensions and bill of material.</p> <p>3.6 Permissible variation in dimensions mentioned in Table-II shall be as follows:</p>		
स्वत्वाधिकार एवं गोपनीय इस दस्तावेज में दी गई सूचना भारत हेवी इलेक्ट्रिकल्स की संपत्ति है इकाई प्रत्येक एवं अप्रत्यक्ष रूप से किसी भी तरह प्रयोग, जो कि कंपनी के हित में स्वत्वाधिकार हो न किया जाए।	<p>i) Nominal dimension : From 30 mm - 120 mm : +/- 2 mm</p> <p>ii) - do - : From 121 mm - 315 mm : +/- 2 mm</p> <p>iii) - do - : From 316 mm - 1000 mm : +/- 3 mm</p> <p>3.7 To cater for continuous operational requirement at the power station, the air exhauster and motor shall be of proven design.</p> <p>3.8 All flanged connections shall be supplied with matching counter flanges along with fasteners to permit trouble free assembly of inter connecting pipelines.</p>		
दिनांक एवं हस्ताक्षर SIGN & DATE 31.8.09	<p>4.0 MATERIAL :</p> <p>The material of construction used should satisfy the operational stresses, i.e. mechanical, thermal and chemical. It should be certified by the supplier that the material quoted by them in the part list has been used and is suitable intended service requirements. Aluminium disc shall be provided between motor and fan .</p>		
सामग्री सूची संख्या INVENTORY P-5718	REV.NO. 05	निर्माणकर्ता WORKED BY ROHIT BANSAL	19/09/09
		जांचकर्ता CHECKED BY M.K.LAHOTI	19/09/09

विनांक एवं EXPIRY SIGN & DATE		<b>उत्पाद मानक (हीप - हरिद्वार)</b>		HE 57008	
		<b>PRODUCT STANDARD (HEEP - HARIDWAR)</b>		पृष्ठ	का
सामग्री सूची संख्या को	<p>5.0 DATA REQUIRED WITH THE BID / OFFER:</p> <p>Supplier to furnish the following data / documents in duplicate along with the offer :</p> <p>5.1 The general arrangement drawing &amp; catalogue / literature relevant to the product.</p> <p>5.2 Part lists</p> <p>5.3 Data sheets duly filled in formats attached with this specification. Foundation drawing along with embossment details of the foundation bolts etc.</p> <p>5.4 The list of recommended spares required for a period of 5 years.</p> <p>6.0 IDENTIFICATION :</p> <p>6.1 The fan exhauster with motor assembly should have name plate of corrosion resistant material and must include the following information :</p> <p>6.11 Name of equipment.</p> <p>6.12 Model No.</p> <p>6.1.3. Motor rating.</p> <p>6.1.4 Name of supplier</p> <p>6.1.5 BHEL specification No He 57008.</p> <p>6.1.6 Identification SI No. 1 or 2, as shown in Figure-2</p> <p>6.1.7 Power factor.</p> <p>6.1.8 Weight of the equipment.</p> <p>6.2 The direction of rotation should be embossed on the equipment at an easily locating position.</p> <p>7.0 INSPECTION AND TESTING:</p> <p>7.1 The final inspection shall be carried out by BHEL'S representative. A notice of minimum 4 weeks shall be given by supplier for witnessing tests / checks for each lot of air-exhauster with motor. Representative shall have free access to the supplier's works for the purpose of inspection and testing of the air exhauster with motor, and vendor shall provide him all necessary help in carrying out the inspection.</p> <p>Approval of tests / inspection and there by issue of test certificates, or waiver of inspection by the purchaser shall not relieve the vendor of his responsibilities and obligations under contract for safe and satisfactory performance of the fans.</p> <p>7.2 Tests listed under clause 7.3 shall be carried out as per procedures laid down in IS : 4894. If facilities for any of the tests mentioned below does not exist with the supplier, then relevant test certificates issued by approved test laboratories / institutes shall be supplied in original. Supplier shall supply all test certificates as listed in clause no 7.3.</p> <p>7.3 Minimum tests / checks to be carried out on air exhauster, are given below.</p>				
कॉपी संख्या	कॉपी संख्या एवं दिनांक	कॉपी संख्या एवं दिनांक	कॉपी संख्या एवं दिनांक	कॉपी संख्या एवं दिनांक	कॉपी संख्या एवं दिनांक
1	2	3	4	5	6
REV.NO.	05	निर्माणकर्ता	ROHIT BANSAL	जांचकर्ता	M.K.LAHOTI
INVENTORY	P-5718	WORKED BY		CHECKED BY	

COPYRIGHT AND CONFIDENTIAL  
 The information on this documents is the property of Bharat Heavy Electrical Limited. It must not be used directly or indirectly in any way detrimental to the interest of the company

स्वत्वाधिकार एवं गोपनीय  
 इस प्रलेख में दी गई सूचना भारत की इलेक्ट्रिकल्स की संपत्ति है इसका प्रत्यक्ष एवं अप्रत्यक्ष रूप से किसी भी तरह प्रयोग, जो कि कंपनी के हित में हानिकारक हो न किया जाए।

19/8/09  
 19/8/09

दिनांक एवं स्थान DATE		<b>उत्पाद मानक (हीप - हरिद्वार)</b>		<b>HE 57008</b>
		<b>PRODUCT STANDARD (HEEP - HARIDWAR)</b>		पृष्ठ का Page 4 of 11
SUPERSEDES INVENTORY NO.	<b>7.3.1 AIR EXHAUSTER:</b> <ul style="list-style-type: none"> <li>i. Air delivery test to meet the requirement of clause 2.3.9.</li> <li>ii. Vibration test, to meet the requirement of clause 2.3.2.</li> <li>iii. Noise level test, to meet the requirement of clause 2.3.3.</li> <li>iv. Dimensional Check</li> <li>v. Material check: Material certificate shall be as per approved drg. / material list by BHEL.</li> <li>vi. Fan speed (Acceptance test).</li> <li>vii. Balancing of rotating parts to meet the requirements of clause 2.3.4</li> <li>viii. 100% soap bubble test shall be carried out for no leakage of Casing &amp; Gasket joints at design pressure.</li> </ul>			
<b>COPYRIGHT AND CONFIDENTIAL</b> The information on this documents is the property of Bharat Heavy Electrical Limited. It must not be used directly or indirectly in any way detrimental to the interest of the company	<b>7.3.2 MOTOR:</b> <ul style="list-style-type: none"> <li>(a) TYPE TESTS:           <ul style="list-style-type: none"> <li>i. Temp. rise test.</li> <li>ii. Power factor test.</li> <li>iii. A. C. leakage test.</li> </ul> </li> <li>(b) ROUTINE TESTS           <ul style="list-style-type: none"> <li>i. High voltage test.</li> <li>ii. Insulation resistance test.</li> <li>iii. Earthing continuity test</li> <li>v. Electrical input test.</li> </ul> </li> </ul>			
<b>स्वत्वाधिकार एवं गोपनीय</b> इस प्रलेख में दी गई सूचना भारत हेवी इलेक्ट्रिकल्स की सम्पत्ति है इसका प्रयोग एवं आरक्षण रूप से किसी भी तरह प्रयोग, जो कि कंपनी के हित में हानिकारक हो न किया जाए।	<b>7.4 TOLERANCE ON RATINGS :</b>  The difference between the observed test results and the ratings assigned by the manufacturer shall not exceed the tolerances given below : <ul style="list-style-type: none"> <li>a) Air delivery (-) 10 %</li> <li>b) Electrical input (+) 10%</li> <li>c) Speed (+/-) 10 %</li> <li>d) Deficiency (-) 15%.</li> </ul>			
31/8/09	<b>8.0 DOCUMENTS REQUIRED ALONG WITH SUPPLY OF EXHAUSTER UNIT SET :</b> <ul style="list-style-type: none"> <li>8.1 Certified copies of test results of tests listed under paragraph 7.2.&amp; 7.3 in 5 copies.</li> <li>8.2 Dimensional drawings showing erection details in 5 nos.</li> <li>8.3 Operating and maintenance manual in 5 nos.</li> <li>8.4 Packing lists.</li> <li>8.5 Final data sheets on the format enclosed with this specification in 5 nos..</li> <li>8.6 Guarantee certificate: The supplier shall guarantee trouble free operation of the equipment for a minimum period of one year after installation and undertake to replace / repair the damaged components free of cost with in the guarantee period.</li> <li>8.7 A copy each of the above-referred documents, along with one reproducible of item at clause 8.2 shall be dispatched separately to BHEL, Hardwar before dispatch of consignment.</li> </ul>			
सामग्री सूची संख्या INVENTORY	REV.NO.  05	निर्माणकर्ता WORKED BY	ROHIT BANSAL	
P-5718		जांचकर्ता CHECKED BY	M.K.LAHOTI	

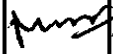
दिनांक एवं हस्ताक्षर SIGN & DATE		<b>उत्पाद मानक (हीप - हरिद्वार)</b>		<b>HE 57008</b>	
		<b>PRODUCT STANDARD (HEEP - HARIDWAR)</b>		पृष्ठ	का
सामग्री सूची संख्या को	SUPERSEDES INVENTORY	9.0 INTER CHANGEABILITY :		Page	5 of 11
<b>COPYRIGHT AND CONFIDENTIAL</b> The information on this documents is the property of Bharat Heavy Electrical Limited. It must not be used directly or indirectly in any way detrimental to the interest of the company	9.0 INTER CHANGEABILITY : The motor of the exhauster of a particular size and model and set of blades shall be Changeable such that the performance of the equipment remains within specified limits.	10.0 QUALITY PLAN :			
		10.0 QUALITY PLAN : Quality Plan shall be submitted along with the offer for approval. Prior approval of Quality Plan is necessary before manufacturing.			
<b>स्वत्वधिकार एवं गोपनीय</b> इस प्रलेख में दी गई सूचना भारत हेवी इलेक्ट्रिकल्स की सम्पत्ति है इका प्रत्यक्ष एवं अप्रत्यक्ष रूप से किसी भी तरह प्रयोग, जो कि कंपनी के हित में हानिकारक हो न किया जाए	11.0 PAINTING : The equipment is to be painted with the paints given below after cleaning the surfaces by shot blasting etc., giving a clean dry and metallic finish.	11.1 INTERNAL SURFACES : Inner chamber of the exhauster are to be preserved with steam Washable preservation oil/ paint having viscosity of 38 centistokes at 40° c.			
		11.2 OUTER SURFACES : Outer surfaces of exhauster shall be painted as per following details : I. Inland conditions: Process a) and c) as per details below to be used for inland application with final DFT as 100 microns. II. Sea Condition : Process a),b) and c) as per details below to be used with final DFT as 100 microns.			
दिनांक एवं हस्ताक्षर SIGN & DATE 31.8.09	12.0 DESPATCH : 12.1 The exhauster units shall be directly dispatched to the site as described in the Purchase Order. 12.2 All openings to be suitably blanked with blanking plates/counter flanges as specified in Cl. 3.8. 12.3 All loose items to be packed separately in a small box and kept inside the main packing box for the exhauster units. 12.4 Packing should be sea worthy and must be able to protect the equipment in tropical climate. 12.5 Following information should be painted on the packing box :	a) Priming : Epoxy resin based 2 pack Zinc Phosphate with DFT 50 microns. b) Intermediate : TiO <sub>2</sub> pigmented epoxy resin intermediate paint. c) Finish : Epoxy resin based finish paint.			
		a) Name of the equipment. b) BHEL Purchase Order No. c) BHEL Specification No. HE-57008.			
सामग्री सूची संख्या INVENTORY P-5718	REV.NO. 05	13.0 LIST OF CROSS REFERRED STANDARDS AND SPECIFICATIONS :		निर्माणकर्ता	
		a) ASME - IX                      b) ISO - 1940                      c) IS - 1401 d) IS - 4691                      e) IS - 4894                      f) IS - 12065 g) IS - 12075		WORKED BY	ROHIT BANSAL
				जांचकर्ता	
				CHECKED BY	M.K.LAHOTI
					 19/8/09

रिनांक एवं हस्ताक्षर SIGN & DATE  
 SUPERSEDES INVENTORY NO.  
 सामग्री सूची संख्या को

**COPYRIGHT AND CONFIDENTIAL**  
 The information on this documents is the property of Bharat Heavy Electrical Limited. It must not be used directly or indirectly in any way detrimental to the interest of the company

**स्वत्वाधिकार एवं गोपनीय**  
 इस प्रलेख में दी गई सूचना भारत हेवी इलेक्ट्रिकल्स की संपत्ति है इसका प्रत्यक्ष एवं अप्रत्यक्ष रूप से किसी भी तरह प्रयोग, जो कि कंपनी के हित में हानिकारक हो न किया जाए।

अवधार एवं रिनांक  
 SIGN & DATE  
 21.8.09

सामग्री सूची संख्या  
 INVENTORY NO.  
 P-5718

REV.NO.  
 05

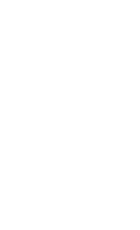

**TABLE-1**

SL. NO.	PARAMETERS	UNIT S	TYPE						
			A	B	C	A1	B1	C1	D
01	SUCTION TEMPERATURE	°C	70	80	84	70	80	84	80
02	HEAD DEVELOPED	mmW C	310	306	410	310	306	410	306
03	FLOW VOLUME	M <sup>3</sup> /se C.	0.3	0.4	0.3	0.3	0.4	0.3	0.7
04	DENSITY OF AIR STEAM MIXTURE AT SUCTION TEMPERATURE AND 85% RH	Kg/M <sup>3</sup>	0.923	0.846	0.780	0.923	0.846	0.780	0.846

निर्माणकर्ता  
 WORKED BY  
 ROHIT BANSAL  
 15/8/09

जांचकर्ता  
 CHECKED BY  
 M.K.LAHOTI  
 19/8/09

दिनांक एवं इस्तेमाल SIGN & DATE



उत्पाद मानक (हीप - हरिद्वार)

HE 57008

PRODUCT STANDARD (HEEP - HARIDWAR)

पृष्ठ का  
Page 7 of 11

सामग्री सूची  
INVENTORY NO.

**COPYRIGHT AND CONFIDENTIAL**  
The information on this documents is the property of Bharat Heavy Electrical Limited. It must not be used directly or indirectly in any way detrimental to the interest of the company

स्वत्वाधिकार एवं गोपनीय  
इस प्रलेख में दी गई सूचना भारत हेवी इलेक्ट्रिकल्स की सम्पत्ति है इसका प्रत्यक्ष एवं अप्रत्यक्ष रूप से किसी भी तरह प्रयोग, जो कि कंपनी के हित में हानिकारक हो न किया जाए।

करताकार एवं दिनांक  
SIGN & DATE  
31.8.09

सामग्री सूची संख्या  
INVENTORY NO.  
P-5718

REV.NO.  
05

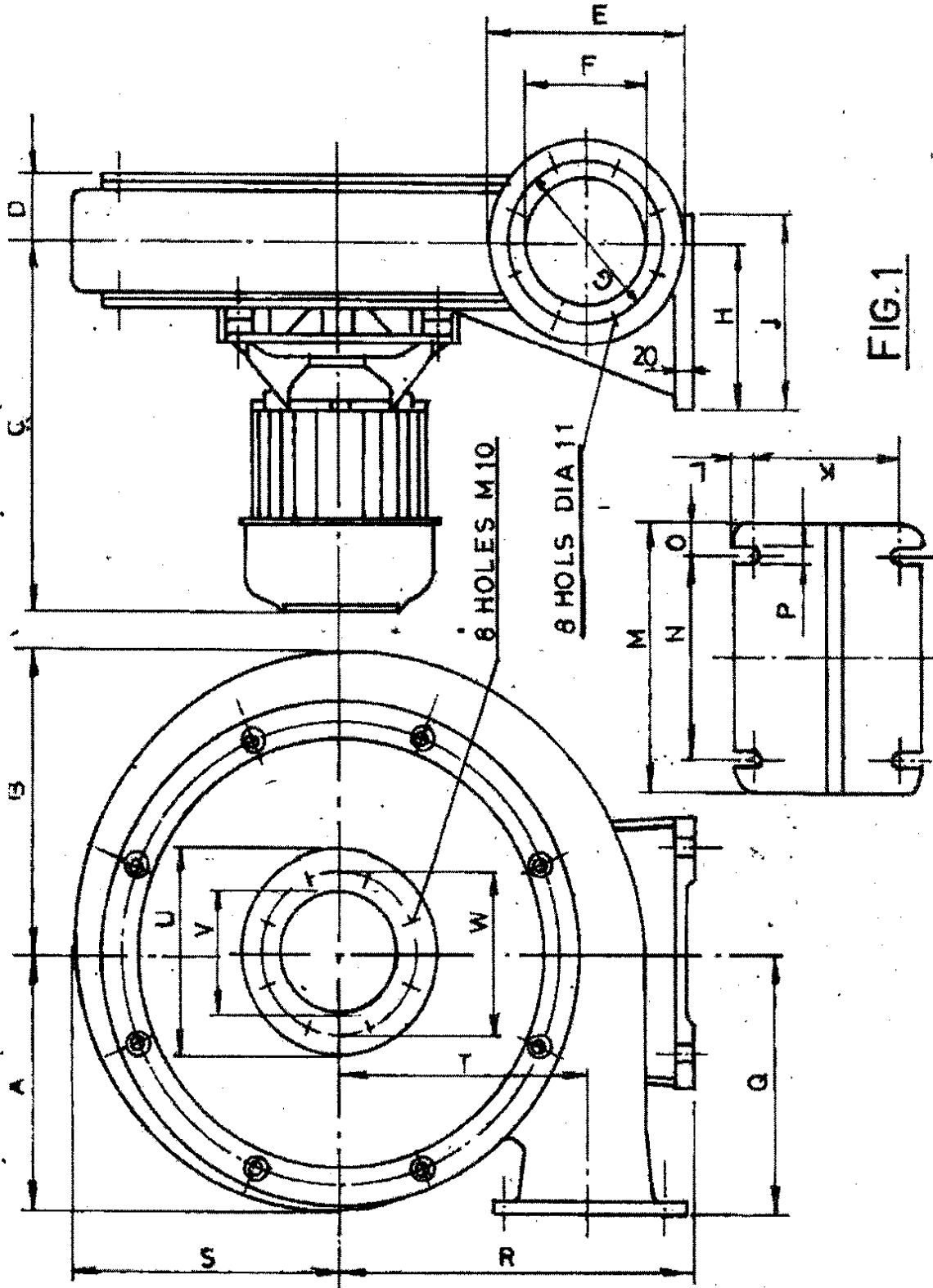

निर्माणकर्ता  
WORKED BY

ROHIT BANSAL

13/8/09

जांचकर्ता  
CHECKED BY

M.K.LAHOTI

19/8/09

दिनांक एवं इस्तेमाल SIGN & DATE



उत्पाद मानक (हीप - हरिद्वार)

HE 57008

पृष्ठ का  
Page 8 of 11

PRODUCT STANDARD (HEEP - HARIDWAR)

SUPERSEDES INVENTORY NO

COPYRIGHT AND CONFIDENTIAL  
The information on this documents is the property of Bharat Heavy Electrical Limited. It must not be used directly or indirectly in any way detrimental to the interest of the company

स्वत्वाधिकार एवं गोपनीय  
इस दस्तावेज में दी गई सूचना भारत हेवी इलेक्ट्रिकल्स की सम्पत्ति है इस्तेमाल के बिना अनुमति के इस दस्तावेज को किसी भी तरह प्रयोग, जो कि कंपनी के हित में हानिकारक हो न किया जाए।

कर्मचारक एवं दिनांक  
SIGN & DATE  
31.8.09

सामग्री सूची संख्या  
INVENTORY  
P-5718

DIMENSIONAL DETAIL OF FIGURE-1

SL NO	TYPE DIMENSION	A	B	C	A1	B1	C1	D
01	A	≈212	≈263	≈263	≈300	≈300	≈360	≈360
02	B	≈268	≈318	≈318	≈350	≈350	≈425	≈425
03	C	≈445	≈450	≈425	≈540	≈540	≈560	≈540
04	D	72	80	80	115	115	135	135
05	E	φ 216	φ234	φ234	φ234	φ234	φ274	φ280
06	F	φ140	φ160	φ160	φ160	φ160	φ200	φ200
07	G (PCD)	φ182	φ200	φ200	φ200	φ200	φ240	φ240
08	H	172	180	180	180	180	210	243
09	J	200	200	200	243	243	243	343
10	K	164	164	164	207	207	207	307
11	L	18	18	18	18	18	18	18
12	M	250	280	280	364	364	364	464
13	N	190	220	220	304	304	304	404
14	O	30	30	30	30	30	30	30
15	P	18	18	18	18	18	18	18
16	Q	215	270	270	320	320	380	400
17	R	330	390	390	440	440	530	530
18	S	≈240	≈284	≈284	≈325	≈325	≈390	≈390
19	T	220	267	267	310	310	370	370
20	U	φ216	φ234	φ234	φ234	φ234	φ274	φ280
21	V	φ140	φ160	φ160	φ160	φ160	φ200	φ200
22	W (PCD)	φ182	φ200	φ200	φ200	φ200	φ240	φ240

REV.NO.  
05

निर्माणकर्ता WORKED BY	ROHIT BANSAL	<i>[Signature]</i>	19/8/09
जांचकर्ता CHECKED BY	M.K.LAHOTI	<i>[Signature]</i>	19/8/09



**सामग्री सूची संख्या को**

**SUPERSEDES INVENTORY**

**स्वतंत्रतादिनांक एवं गोपनीय**

The information on this documents is the property of Bharat Heavy Electrical Limited. It must not be used directly or indirectly in any way detrimental to the interest of the company

**स्वतंत्रतादिनांक एवं गोपनीय**

इस प्रलेख में दी गई सूचना भारत हेवी इलेक्ट्रिकल्स की संपत्ति है इसका प्रयोग एवं आभारका रूप से किसी भी तरह प्रयोग, जो कि कंपनी के हित में फायदेकारक हो न किया जाए।

दिनांक एवं  
SIGN & DATE

*[Signature]*  
31.8.09

सामग्री सूची संख्या  
INVENTORY

P-5718

**AIR EXHAUSTERS TO BE SUPPLIED IN PAIRS AS PER ORIENTATION\* BELOW**

\* Air Exhausters suitable for flexible orientation (in addition to mirror image orientation) shall be preferred. This can be achieved if the design permits rotation of air outlet connection together with casing by 180°, keeping the bed plate position unchanged.



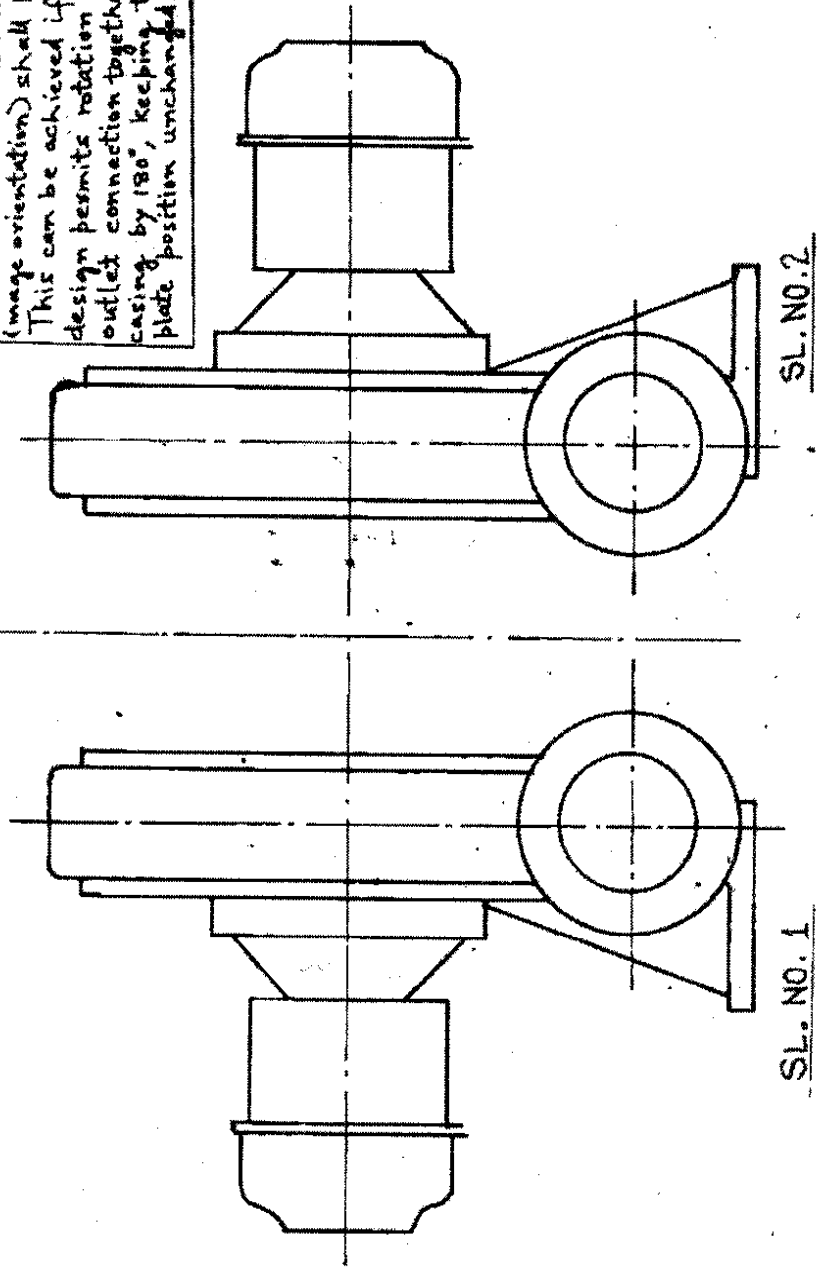

REV.NO.  
05



**FIG-2**

निर्माणकर्ता WORKED BY	ROHIT BANSAL	<i>[Signature]</i>	15/8/09
जांचकर्ता CHECKED BY	M.K.LAHOTI	<i>[Signature]</i>	19/8/09

निर्माक एवं हस्ताक्षर SIGN & DATE		<b>उत्पाद मानक (हीप - हरिद्वार)</b>		HE 57008	
		<b>PRODUCT STANDARD (HEEP - HARIDWAR)</b>		पृष्ठ	का
सामग्री सूची संख्या को	<b>DATA SHEET</b>				
<b>COPYRIGHT AND CONFIDENTIAL</b> The information on this documents is the property of Bharat Heavy Electrical Limited. It must not be used directly or indirectly in any way detrimental to the interest of the company	<b>A. FAN</b>				
	स्वत्वाधिकार एवं गोपनीय इस प्रलेख में दी गई सूचना भारत हेवी इलेक्ट्रिकल्स की संपत्ति है इसका प्रत्यक्ष एवं अप्रत्यक्ष रूप से किसी भी तरह प्रयोग, जो कि कंपनी के हित में हानिकारक हो न किया जाए।	<ol style="list-style-type: none"> <li>1. Name of manufacturer</li> <li>2. Model No.</li> <li>3. Position</li> <li>4. Flow dry air M<sup>3</sup> / sec</li> <li>5. Pressure difference k p a</li> <li>6. Flow steam mixture m<sup>3</sup> / sec</li> <li>7. Mixture temp</li> <li>8. Pressure difference k p a (with air steam mixture)</li> <li>9. Arrangement to with stand 350 °C (during abnormal operation)</li> <li>10. Density of mixture kg / m<sup>3</sup></li> <li>11. Density of medium during test kg / m<sup>3</sup></li> <li>12. Power absorbed K W</li> <li>13. Speed RIM</li> <li>14. Weight of rotating part kg</li> <li>15. Weight of fan exhauster kg</li> <li>16. Moment of inertia kg m<sup>2</sup></li> <li>17. Standard and degree of rotor balancing</li> </ol>			
कल्लेखर एवं तिनांक SIGN & DATE	<b>B. MOTOR:</b>				
31.8.09	<ol style="list-style-type: none"> <li>1. Model No.</li> <li>2. Rating K W</li> <li>3. Rated voltage</li> <li>4. Frequency 50 Hz</li> <li>5. Speed R P M</li> <li>6. Degree of protection</li> <li>7. Rated current amp</li> </ol>				
सामग्री सूची संख्या INVENTORY	REV.NO.	निर्माणकर्ता WORKED BY		ROHIT BANSAL	
P-5718	05	जांचकर्ता CHECKED BY		M.K.LAHOTI	
				15/8/09 19/8/09	

दिनांक एवं हस्ताक्षर SIGN & DATE		<p align="center"><b>उत्पाद मानक (डीप - हरिद्वार)</b></p> <p align="center"><b>PRODUCT STANDARD (HEEP - HARIDWAR)</b></p>	<p align="right">HE 57008</p> <p align="right">पृष्ठ का Page 11 of 11</p>	
सामग्री सूची संख्या को SUPERSEDES INVENTORY NO.	<ol style="list-style-type: none"> <li>8. Power factor</li> <li>9. Starting current Amp</li> <li>10. Temp. Rise over 50 °C ambient, °C</li> <li>11. Class of insulation</li> <li>12. Rated torque - NM</li> <li>13. Starting torque -NM</li> <li>14. Weight of rotating part, Kg</li> <li>15. Weight of motor - Kg</li> <li>16. Moment of inertia K g-m<sup>2</sup>.</li> </ol> <p>C. ASSEMBLY:</p> <ol style="list-style-type: none"> <li>1. Weight, Kg</li> <li>2. Foundation bolts &amp; nut – Yes</li> <li>3. Drawing No.</li> </ol>			
<b>COPYRIGHT AND CONFIDENTIAL</b> The information on this documents is the property of Bharat Heavy Electrical Limited. It must not be used directly or indirectly in any way detrimental to the interest of the company				
<b>स्वत्वाधिकार एवं गोपनीय</b> इस प्रलेख में दी गई सूचना भारत डीपी इलेक्ट्रिकल्स की सम्पत्ति है इसका प्रत्यक्ष एवं अप्रत्यक्ष रूप से किसी भी तरह प्रयोग, जो कि कंपनी के हित में हानिकारक हो न किया जाए।				
कर्ता/दिनांक एवं दिनांक SIGN & DATE  31.8.09				
सामग्री सूची संख्या INVENTORY P-5718	REV.NO. 05		निर्माणकर्ता WORKED BY ROHIT BANSAL	 19/8/09
			जांचकर्ता CHECKED BY M.K.LAHOTI	 19/8/09