

SECTION-AA

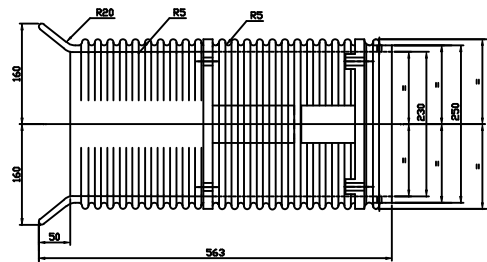
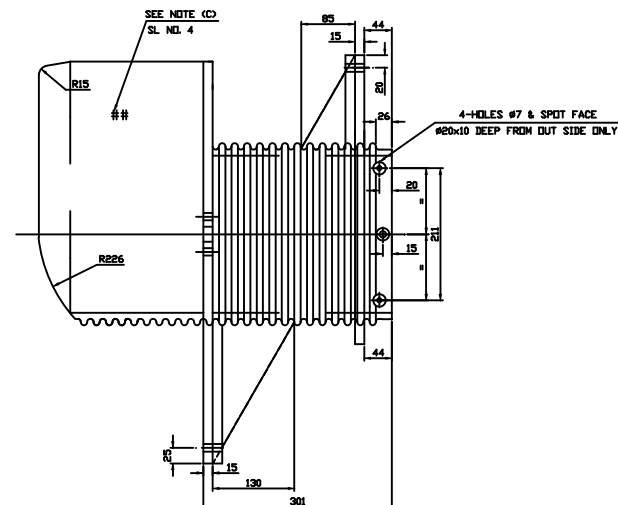
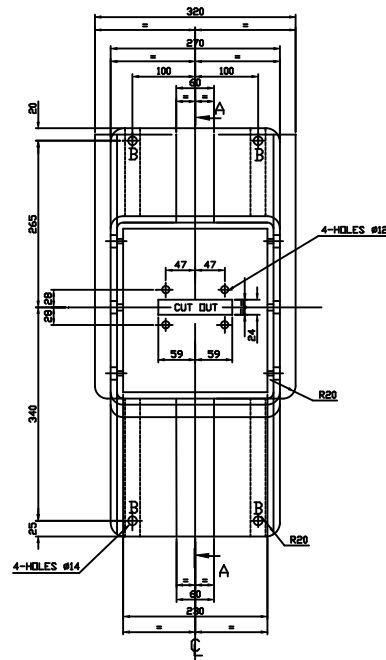

**(A) TECHNICAL PARTICULARS**

1. SEAL OFF BUSHING SHOULD BE MOLDDED FROM CAST EPOXY RESIN CONFORMING TO STANDARD BP22463 OR EQUIVALENT ED.
2. MINIMUM CREEPAGE DISTANCE BETWEEN LOCATIONS MARKED 'DD' IN DETAIL 'X' SHOULD BE 600 MM.
3. COLOUR : RED.
4. FINISH : MATERIAL SHOULD BE SMOOTH, COMPACT BRIGHT AND FREE FROM FOREIGN INCLUSIONS WITH UNIFORMLY DISTRIBUTED BONDS.

**(B) TYPE TEST**

- FOLLOWING TYPE TESTS SHALL BE CONDUCTED ON ONE SAMPLE BEFORE BULK MANUFACTURING IN LINE WITH IS 9491.
1. LIGHTNING IMPULSE VOLTAGE TEST AT 170 KVP (CL-9-2) TEST SETUP AS SPECIFIED IN DETAIL 'X'.
  2. H.V. TEST AT 70 KV RMS FOR 1 MIN. (CL. 9.3) TEST SETUP AS SPECIFIED IN DETAIL 'X'.
  3. PARTIAL DISCHARGE TEST (CL. 9.4) VALUE 10 PICO COULDN IS MAXIMUM.
  4. WATER ABSORPTION TEST (CL. 9.5).
  5. FLAMMABILITY TEST (CL. 9.11).
  6. AGING & HUMIDITY TEST (CL. 9.10).
  7. CANTI LEVER LOAD TEST (CL. 9.6) TEST SETUP AS PER DETAIL 'Y'.

**(C) ACCEPTANCE CRITERIA**

1. DIMENSIONAL CHECKS AS PER DRAWING.
2. SUCCESSFUL COMPLETION OF TYPE TESTS ON ONE SAMPLE AS SPECIFIED IN CL. (B) ABOVE.
3. H.V. TEST AT IN 70 KV RMS / 1 MIN IN EVERY PIECE.
4. MANUFACTURER LOGO, BATCH NO., MONTH AND YEAR OF MANUFACTURING TO BE EMBOSSED/PRINTED (STICKER NOT ACCEPTABLE) AT LOCATION MARKED 'H'.

**(D) PACKING**

ITEM SHOULD BE PACKED IN WATERPROOF / AIRPROOF PACKING.

**(E) PATENT**

BHEL HAS APPLIED PATENT FOR THIS ITEM. THIS ITEM/ DRAWINGS CAN NOT BE SUPPLIED TO ANY PARTY WITHOUT WRITTEN PERMISSION OF BHEL.

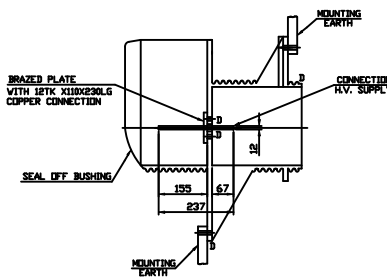

DETAIL-X

ARRANGEMENT FOR H.V. TEST & IMPULSE VOLTAGE TEST

SCALE 1:2

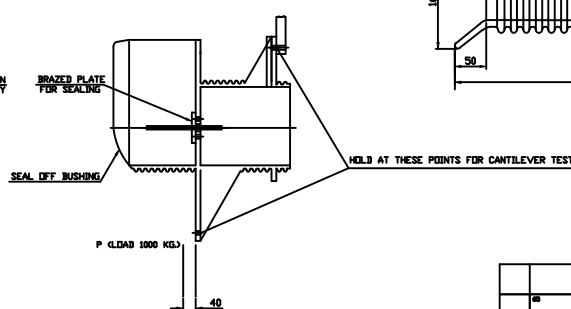

DETAIL-Y

ARRANGEMENT FOR CANTILEVER TEST

SCALE 1:2

VAR	REMARKS	DATE	BY	DESCRIPTION	DRAWING NO.	SCALE	MATL. CODE	UNIT	MT.	QTY.

REV	DATE	ALTERED	CHKD	DATE	ALTERED	CHKD	DATE	ALTERED	CHKD
01	21.9.08	CHECKED	APPROVED	01	21.9.08	CHECKED	APPROVED	01	21.9.08
02	25.08.07	CHECKED	APPROVED	03	30.08.07	CHECKED	APPROVED	03	30.08.07
03	01.02.10	CHECKED	APPROVED	04	01.02.10	CHECKED	APPROVED	04	01.02.10

REV	DATE	ALTERED	CHKD	DATE	ALTERED	CHKD	DATE	ALTERED	CHKD
01	21.9.08	CHECKED	APPROVED	01	21.9.08	CHECKED	APPROVED	01	21.9.08
02	25.08.07	CHECKED	APPROVED	03	30.08.07	CHECKED	APPROVED	03	30.08.07
03	01.02.10	CHECKED	APPROVED	04	01.02.10	CHECKED	APPROVED	04	01.02.10

REV	DATE	ALTERED	CHKD	DATE	ALTERED	CHKD	DATE	ALTERED	CHKD
01	21.9.08	CHECKED	APPROVED	01	21.9.08	CHECKED	APPROVED	01	21.9.08
02	25.08.07	CHECKED	APPROVED	03	30.08.07	CHECKED	APPROVED	03	30.08.07
03	01.02.10	CHECKED	APPROVED	04	01.02.10	CHECKED	APPROVED	04	01.02.10

REV	DATE	ALTERED	CHKD	DATE	ALTERED	CHKD	DATE	ALTERED	CHKD
01	21.9.08	CHECKED	APPROVED	01	21.9.08	CHECKED	APPROVED	01	21.9.08
02	25.08.07	CHECKED	APPROVED	03	30.08.07	CHECKED	APPROVED	03	30.08.07
03	01.02.10	CHECKED	APPROVED	04	01.02.10	CHECKED	APPROVED	04	01.02.10

VM 36

SEAL OFF BUSHING

15225001544 05