

2501122112
ON SHIPWARD

THE JUNCTION BOX (J.B.) WITH AMPLIFIER AND CAPACITOR MODULE SHALL COMPRISE OF FOLLOWING ITEMS:-

- ITEM NO. 1- AMPLIFIER MODULE: (MATCHED TO PROPORTIONAL VALVE STW 0115 (ZERO POINT TRIMMING))
- 1.1 TYPE : VT 17399-1X
 - 1.2 POWER SUPPLY : 24V DC
 - 1.3 ALLOWED TOLERANCE : + 15%, -20%
 - 1.4 AMBIENT TEMP : 0 TO 60° C.
 - 1.5 INPUT COMMAND : 4-20mA
 - 1.6 OUTPUT : SUITABLE TO DRIVE PROPORTIONAL VALVE COILS.
 - 1.7 MODULE SHALL HAVE INBUILT POSITION CONTROLLER.
 - 1.8 POSITION FEEDBACK MEASUREMENT TO BE PROVIDED ON THE PROPORTIONAL VALVE AND FED BACK TO THE POSITION CONTROLLER OF AMPLIFIER MODULE.
- ITEM NO. 2- CAPACITOR MODULE (MODEL NO. VT 11073) :
- 2.1 MATCHING CAPACITOR MODULE VT 11073 WITH POLARITY REVERSAL PROTECTION, OVER VOLTAGE PROTECTION & FUSE TO BE PROVIDED.
- ITEM NO. 3- JUNCTION BOX (PG65) WITH SUITABLE CABLE GLANDS (PG-11) :
- 3.1 AMPLIFIER MODULE & CAPACITOR MODULE SHALL BE MOUNTED ON DIN RAIL IN A SUITABLE LOCAL JUNCTION BOX JB(PG65) TO BE SUPPLIED BY THE VENDOR.
 - 3.2 DIMENSIONS OF JUNCTION BOX ARE APPROXIMATE.
 - 4.0 OTHERS REQUIREMENTS:
 - 4.1 ITEM NO. 1 & 2 SHALL BE SUITABLE TO PROPORTIONAL VALVE TYPE- STW 0115-1X/X2-40/V.
 - 4.2 FUNCTIONAL TEST TO BE CARRIED OUT AT PURCHASER'S WORKS.
 - 4.3 CONFIRMATION OF OPERATING TIME WITHOUT OVERHAUL OF MIN. 24000hr.
 - 4.4 ASSEMBLY POSITION ARBITRARY.
 - 4.5 PAINT : RESISTANCE TO PHOSPHATE ESTER (ON EPOXY RESIN BASE OR D/D VARNISH)
 - 4.6 PACKING: ITEM NO.1, 2 & 3 SHALL BE SUPPLIED IN ASSEMBLED AND PACKED CONDITION. TRANSPORT WITHOUT DAMAGE SHALL BE ENSURED BY THE SUPPLIER. SPECIAL STORAGE INSTRUCTIONS FOR ELECTRONIC MODULES TO BE FURNISHED BY THE VENDOR.
 - 4.7 ALL OTHER DATA AS PER BROCHURE.
 - 4.8 MAKE : M/S BOSCH REXROTH OR EQUIVALENT.

TABLE-1 :-

AMPLIFIER MODULE	PROPORTIONAL VALVE STW0115
VT 17399 COMMAND SIGNAL	
4mA	100% P-B
12mA	BALANCE POSITION
20mA	100% P-A

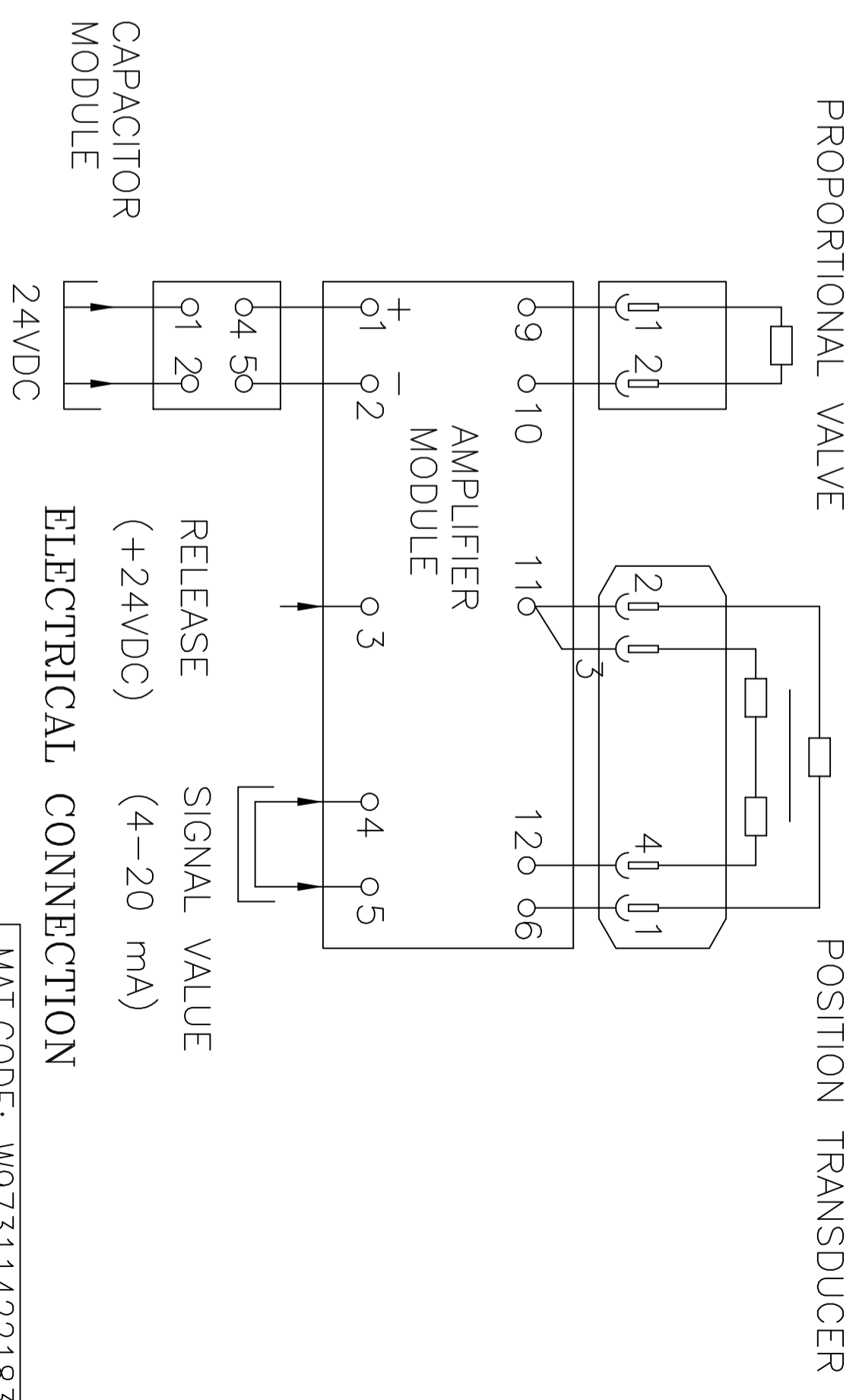
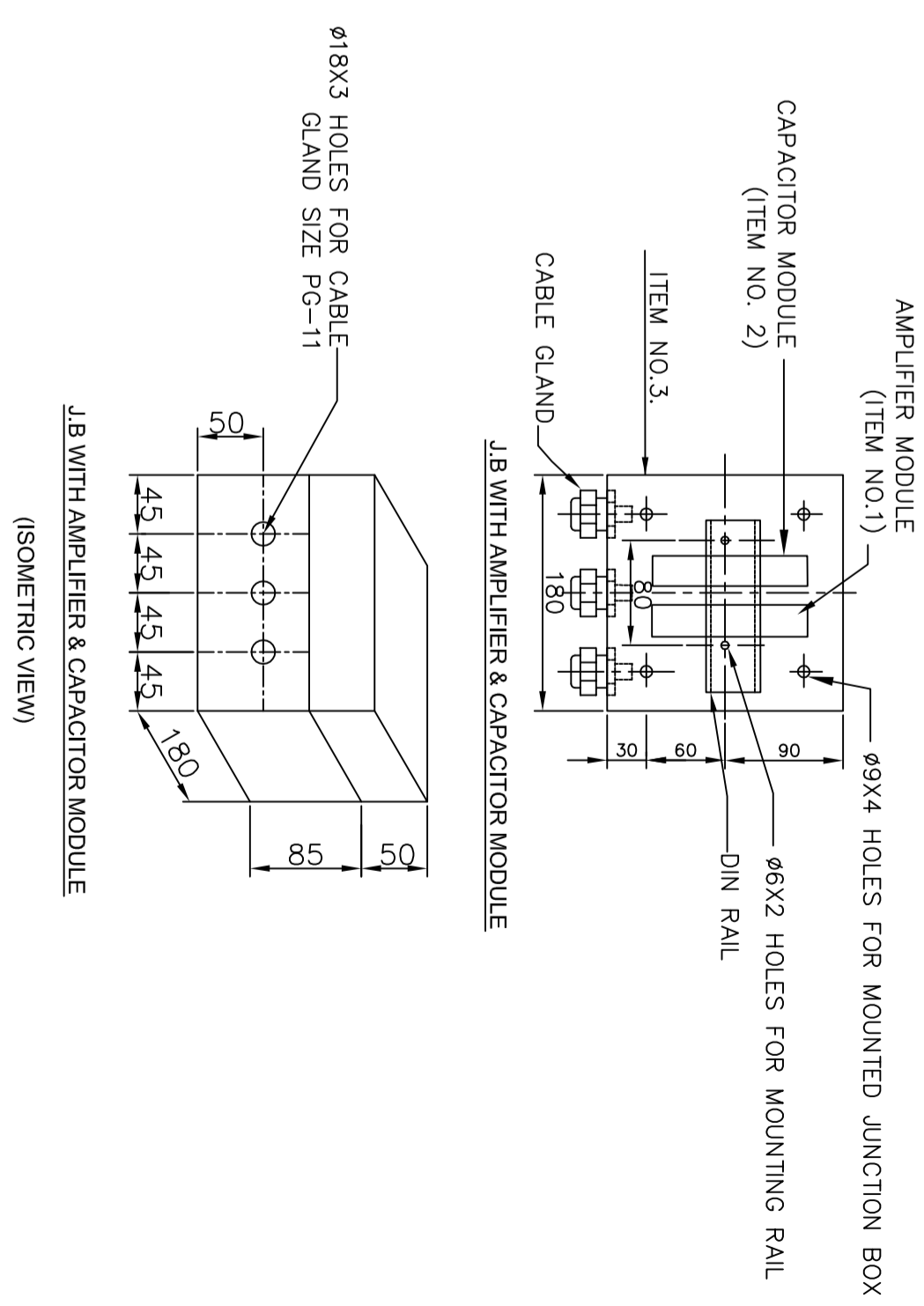

MAT.CODE: W97311422183

COPYRIGHT AND CONFIDENTIAL
THE INFORMATION ON THIS DOCUMENT IS THE PROPERTY OF BHARAT HEAVY ELECTRICALS LIMITED
IT MUST NOT BE USED DIRECTLY OR INDIRECTLY IN ANY WAY DETRIMENTAL TO THE INTEREST OF THE COMPANY.

INVENTORY NO.	SIGN & DATE	REF. DRG NO.
---------------	-------------	--------------

8	7	6	5	4	3
---	---	---	---	---	---

GRADE OF UNTOL. DIM:-	
M/CG - V/C/M/F AA 0230208	
WELDING-A/B/C/D-AA621104	
GAS CUTTING-T3AA0621101	
REV. DATE	ALTERED CHECKED

OBOM NO.	31142211050	STATUS OF DRG.	
AGREED DEPT.	AMINDIO	NAME	ASB/DK
TDR	11/11/2010	SIGN	
DATE		DATE	
REV. DATE	ALTERED CHECKED	REV. DATE	ALTERED CHECKED

TYPE OF PRODUCT OR NAME OF CUSTOMER/ PROJECT		STEAM TURBINE	
DEPT. SITE		BHARAT HEAVY ELECTRICALS LTD. HARDWAR	
CODE 4011	SCALE N.T.S.	WEIGHT(Kg.) 1.5	DRAWING NO. 21142211052
			SHEET NO. 1
			NO. OF SHEETS 1
			DATE 22.12.24
			NO. OF SHEETS 1