

FIRST ANGLE PROJECTION

(ALL DIMENSIONS ARE IN mm)

THE INFORMATION ON THIS DOCUMENT IS THE PROPERTY OF BHARAT HEAVY ELECTRICALS LTD. IT MUST NOT BE USED DIRECTLY OR INDIRECTLY IN ANY WAY DETRIMENTAL TO THE INTEREST OF THE COMPANY.

DRG. NO. 3 452 77 00241

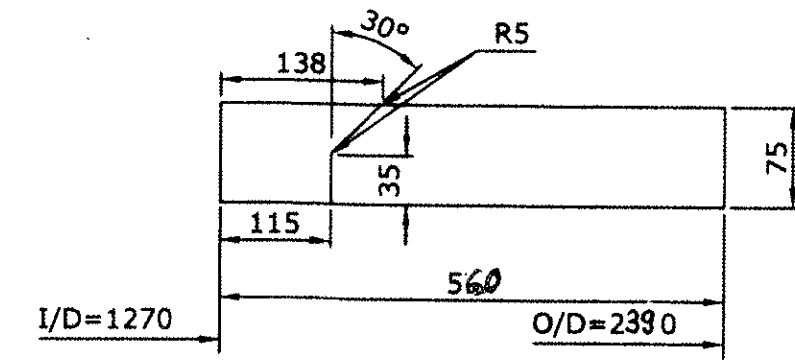
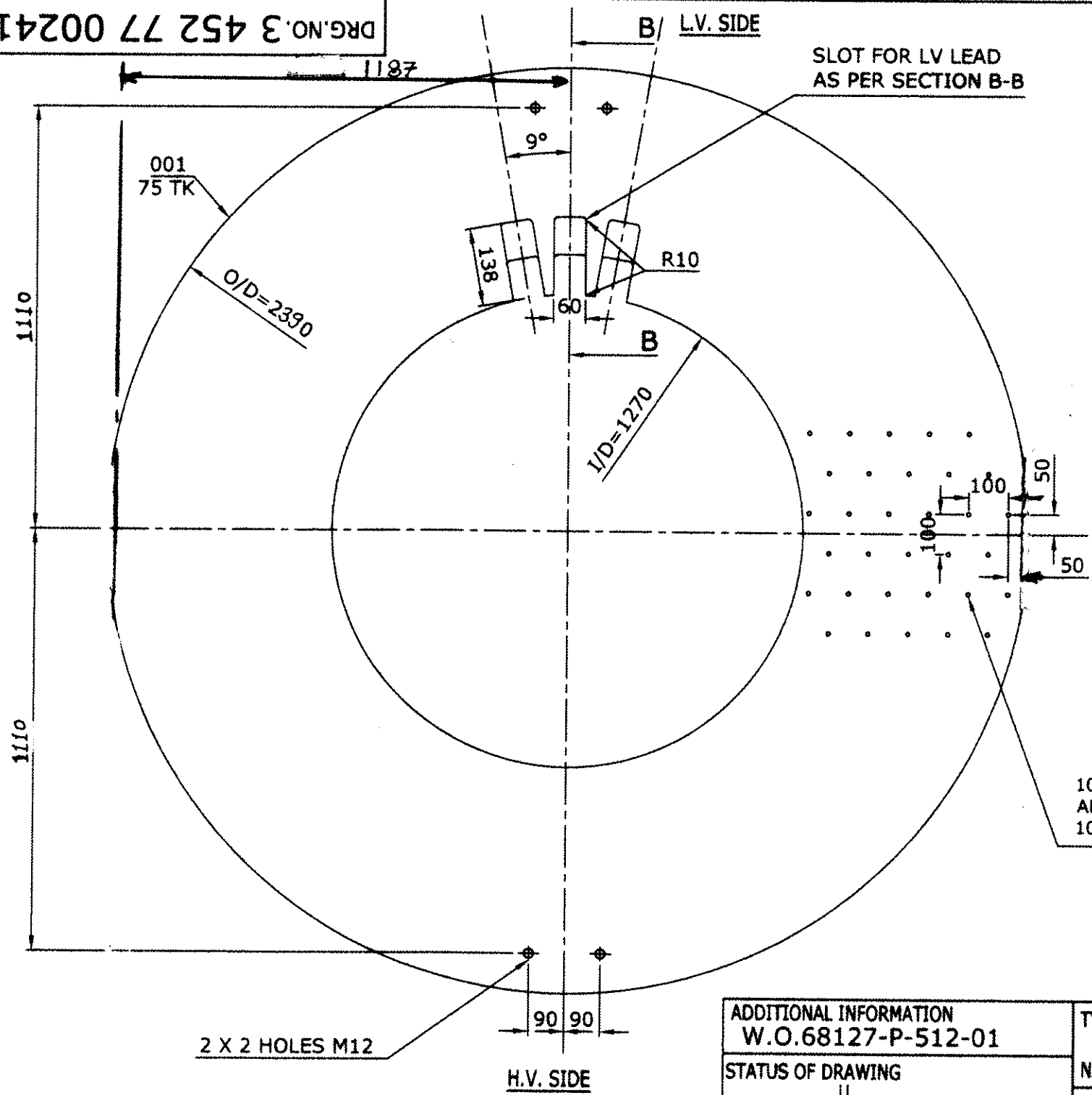

SECTION B-B
SEE NOTE-1

10 DIA HOLES THROUGH ALL OVER THE SLOT ON 100 PITCH AS SHOWN

NOTES:

1. ALL SHARP CORNERS TO BE ROUNDED OFF SMOOTHLY TO R5 RAD.
2. Ø10 HOLES GIVEN FOR OIL IMPREGNATION. SUPPLIER CAN OFFER THEIR ARRANGEMENT WITHOUT AFFECTING STRENGTH OF RING.
3. FOR B.O.M REFER DELINK BOMNO 34527700241.
4. FOR TOLERANCES REFER STD.SHT TR 10112-T.

INVENTORY NO.	SIGN. DATE	REF. DRG. NO.

ADDITIONAL INFORMATION W.O.68127-P-512-01			TYPE OF PRODUCT 260 MVA , 21/420/√3 KV 1 PH GT						
STATUS OF DRAWING U			NAME OF CUSTOMER/PROJECT NTPC, BARH-II						
DISTRIBUTION OF PRINTS TRE TRM TRX 1 3 1			BHARAT HEAVY ELECTRICALS LTD. BHOPAL			NAME DRN PKP CHD AKP APPD AKP/AD	SIGN [Signature]	DATE 11.11.09 12.11.09 12.11.09	NO. OF VAR - -
REV	DATE	ALTERED CHECKED APPROVED	DEPT TRE CODE 406	UNFOI DIMS GR.	SCALE	WEIGHT(kg) 302.00	REF TO ASSY DRG. 0 452 77 00035	ITEM NO. 018	NO.OF ITEM
TITLE TOP RING						DRAWING NO. 3 452 77 00241		REV 00	
SHEET NO. 1						NO. OF SHEETS 1			