

THE INFORMATION ON THIS DOCUMENT IS THE PROPERTY OF BHARAT HEAVY ELECTRICALS LIMITED IT MUST NOT BE USED DIRECTLY OR INDIRECTLY IN ANY WAY DETRIMENTAL TO THE INTEREST OF THE COMPANY

FIRST ANGLE PROJECTION

(ALL DIMENSIONS ARE IN mm)

DRG. NO. 35225002564

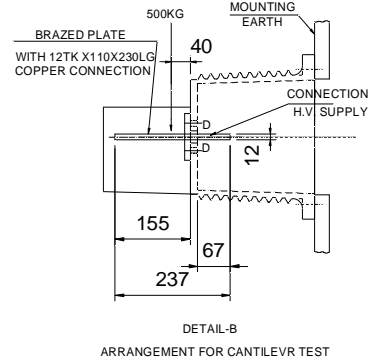
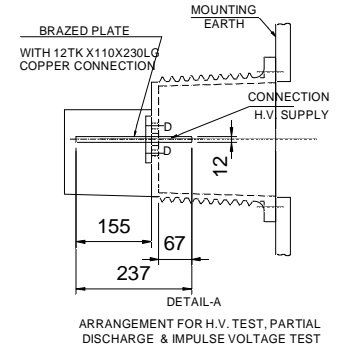
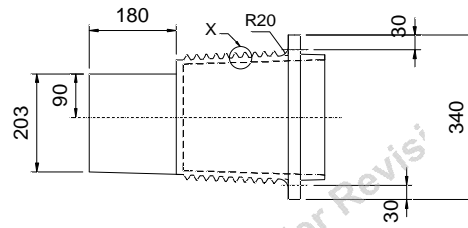
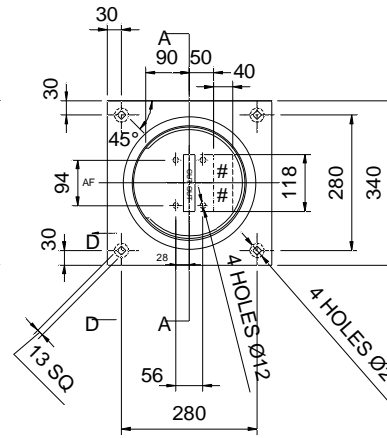
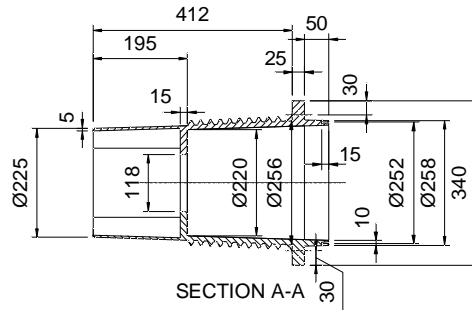
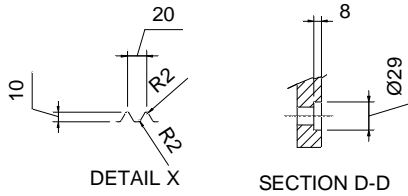

- A) TECHNICAL PARTICULARS:**  
 1. SEAL OFF BUSHING SHOULD BE MOULDED FROM CAST EPOXY RESIN CONFORMING TO STANDARD BP22463 OR EQUIVALENT.  
 RESIN: CY205 / BP 22463  
 H:320:HARDNER:HY905  
 F:Z:FILLER: SILICA FLOOR  
 2. ALL UNSPECIFIED RADII R5.
- B) TYPE TESTS:**  
 FOLLOWING TYPE TESTS SHALL BE CONDUCTED ON ONE SAMPLE BEFORE BULK MANUFACTURING IN LINE WITH IS 9431.  
 1. LIGHTENING IMPULSE VOLTAGE TEST AT 170 KVP (CL-9-2) TEST SETUP AS SPECIFIED IN DETAIL 'A'.  
 2. H.V. TEST AT 70 KV rms FOR 1 MIN. (CL. 9.3) TEST SETUP AS SPECIFIED IN DETAIL 'A' FOR IT.001.  
 3. PARTIAL DISCHARGE TEST (CL. 9.4) VALUE 10 PICO COULOMBS MAX.  
 4. WATER ABSORPTION TEST (CL. 9.9).  
 5. FLAMMABILITY TEST (CL. 9.11).  
 6. AGING & HUMIDITY TEST (CL. 9.10).  
 7. CANTILEVER LOAD TEST (CL. 9.6) TEST SETUP AS PER DETAIL 'B' FOR CANTILEVER LOAD OF 500 KGS.

- C) ACCEPTABILITY CRITERIA:**  
 1. DIMENSIONAL CHECKS AS PER DRAWING.  
 2. SUCCESSFUL COMPLETION OF TYPE TESTS ON ONE SAMPLE.  
 3. H.V. TEST AT IN 70 KV rms / 1 MIN ON EVERY PIECE.  
 4. MANUFACTURER LOGO, BATCH NO., MONTH AND YEAR OF MANUFACTURING TO BE EMBOSSED/PRINTED (STICKER NOT ACCEPTABLE) AT LOCATION MARKED ##, NOT TO EXCEED DIMENSIONS 118 mm x 40 mm.

- D) PACKING:**  
 ITEM SHOULD BE PACKED IN WATERPROOF, AIRPROOF PACKING.

VAR. NO.	REMARKS	VAR. NO.	ITEM NO.	DESCRIPTION	STD.	DRAWING NO.	IT. NO.	MATL. CODE	A/C	UNIT	UNIT WT.	G.S.	ZONE
VAR.							VAR	MATL. SPECN.			QTY.		
			001	EPOXY RESIN MATERIAL									

ADDITIONAL INFORMATION		
STATUS OF DRAWING		
DISTRIBUTION OF PRINTS		
O.C. - 1	SWGR PRO - 3	
TCX - 1		
REV.	DATE	ALTERED
01	5.1.17	rq
		rq
		ad
NOTES ADDED, CREEPAGE ADDED		
DCA		

mRikn dk i-dkj :k  
 xk-gd@fj;kstuk dk uke  
 TYPE OF PRODUCT OR NAME OF CUSTOMER/PROJECT

VM-36

UKG@NAME	qLrk@SGN	frouk@DATE	osfj_ ch la;:k NO. OF VAR
SKG	Sd/-	08.4.16	
RAHUL	Sd/-	08.4.16	00
MAK	Sd/-	08.4.16	

HAKj gsoh bysfDV&yDi fyfeVsm  
 HAKsiky  
 BHARAT HEAVY ELECTRICALS LTD.  
 BHOPAL

fghAkx DEPT SWE  
 wu\_ vky\_ uki ch js.kh UNTOL.DIMS. GR.

dkm 409 CODE

vuqkr SCALE NTS

HAKj fd\_xk- WEIGHT (K.G.)

vrs\_ M&kbZox dk ionHAZ REF. TO ASSY. DRG.

en\_ d- ITEM NO.

en\_ la;:k NO. OF ITEM

vkjs[A d- DRAWING NO.  
 35225002564

iq\_u\_ REV 01

i=7B d-88. No. 01 i=7Bksa ch la;:k. OF SHT. 01

SEAL OFF BUSHING