

SEAL WELD & GRIND  
FLUSH WITH  $\phi 270$

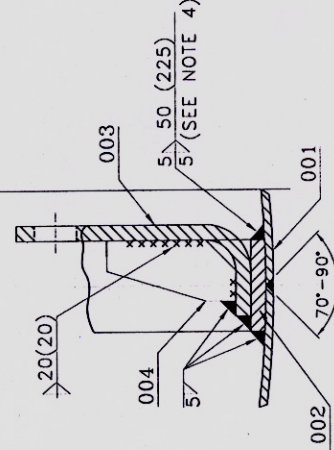
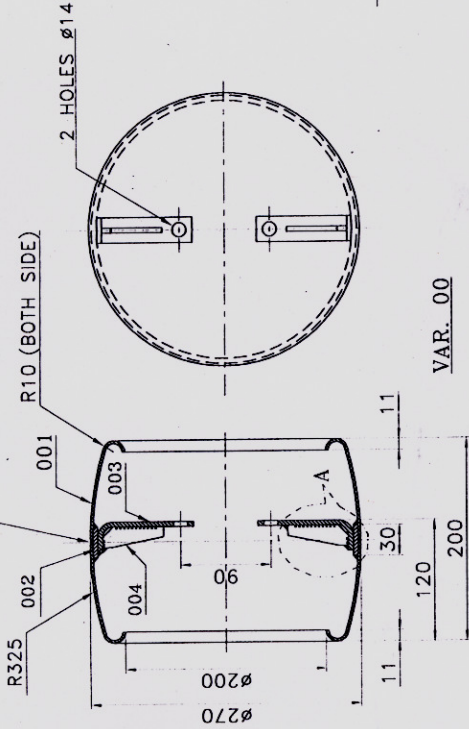

DETAIL - A

VAR. 00

NOTES :-

- ITEMS 003 & 004 TO BE WELD TOGETHER PRIOR TO WELD WITH ITEM 002 IN VAR. 00.
- THE OUTER SURFACE OF THE SHIELD SHOULD BE FREE FROM ANY SHARP EDGES, DENTS, CRACKS & SHOULD HAVE A UNIFORM SMOOTH FINISH.
- OUTER SURFACE OF THE SHIELD TO BE SPRAY PAINTED WITH EPI-LUX-4 ENAMEL SYSTEM AS PER PROCESS SPECIFICATION NO. 0672579. THIS WILL BE DONE BY BHEL.
- 50 MM SPACE WELDING AT 4 PLACES (BOTH SIDES) EQUALLY DISTRIBUTED BY TIG/MIG AS SHOWN.

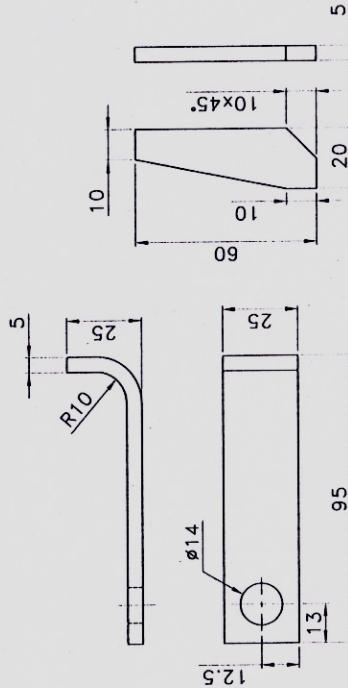

ITEM 004

ITEM 003

VAR. NO.	REMARKS	75	76	78	79	25	27	29	58	59	60	64	65	71	28	31	34	MATL. CODE	45	55	57	58	UNIT WT.	65	72	
VAR. NO.	REMARKS	IT. NO.	DESCRIPTION	DRAWING NO.	VAR. NO.	ITEM NO.	NO.	NO.	NO.	NO.	NO.	NO.	NO.	NO.	NO.	NO.	NO.	NO.	NO.	NO.	NO.	NO.	NO.	NO.	NO.	
2	-	004	5 TK.x20x60LG. AL. ALLOY PLATE	-	1	-	-	-	AA	12312	-	-	-	-	-	-	-	AA	12312	-	-	-	-	-	KG	0.016
2	-	003	5 TK.x25x115LG. AL. ALLOY PLATE	-	1	-	-	-	AA	12312	-	-	-	-	-	-	-	AA	12312	-	-	-	-	-	KG	0.390
1	-	002	5 TK.x30x816 AL. ALLOY PLATE	-	1	-	-	-	AA	12312	-	-	-	-	-	-	-	AA	12312	-	-	-	-	-	KG	0.340
2	-	001	2.6 TK.x125x840LG. AL. ALLOY SHEET	-	1	-	-	-	AA	12312	-	-	-	-	-	-	-	AA	12312	-	-	-	-	-	KG	0.740

- 28 CARD TYPE-3 28 - CARD TYPE-1

28 - CARD TYPE-2

ADDITIONAL INFORMATION

STATUS OF DRAWING

DISTRIBUTION OF PRINTS

BCE - 1 BCM - 4

OCC - 1 TRX - 1

TYPE OF PRODUCT OR NAME OF CUSTOMER/PROJECT 245 KV-2000A O.I.P. COND. BUSHING

NAME	SIGN	DATE	NO. OF
PRADEEP	<i>[Signature]</i>	14.10.14	VAR.
S.C.SOY	<i>[Signature]</i>	14.10.14	01
M.KURRE	<i>[Signature]</i>	15.10.14	

DEPT.	BCE	UNTO. DIMS. GR.	SCALE	WEIGHT(K.G.)
BHEL			1:1 & 1:3	3.000

REV.	DATE	ALT.	CHD.	APPD.	REF. TO ASSY DRG.	ITEM NO.	NO. OF
					0 538 01 01023	041	004

TITLE	DRAWING NO.	REV.
BOTTOM STRESS SHIELD ASSY. FABRICATED	3 538 04 01280	00

SHT. NO.	NO. OF SHT.
01	01

A3 SIZE