

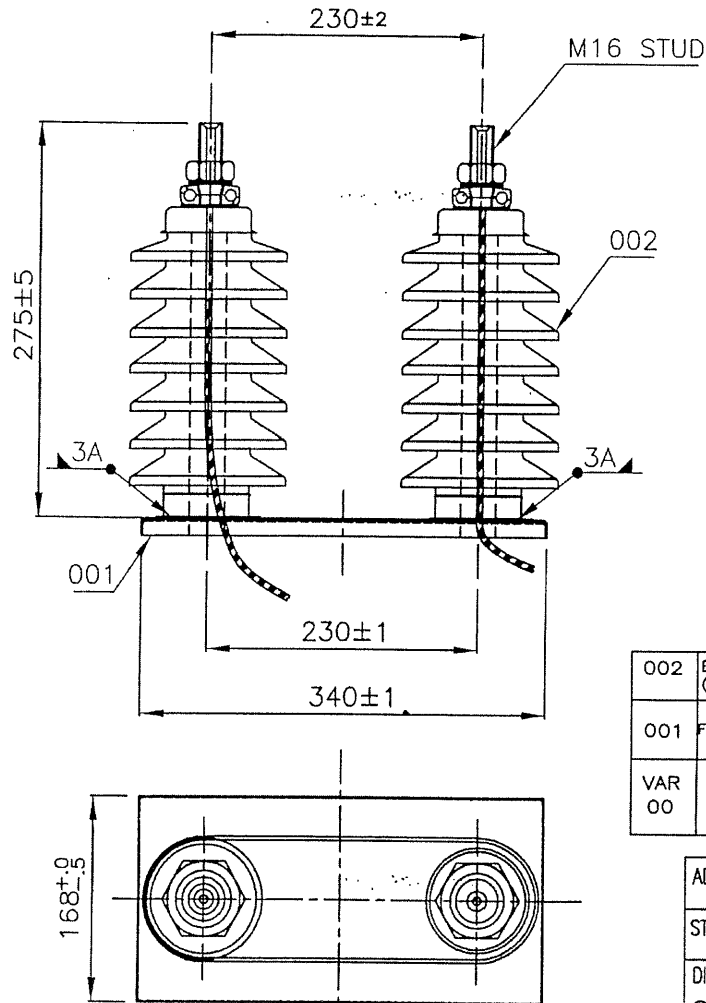

DRG. NO. 3 614 02 00088

BHARAT HEAVY ELECTRICALS LTD.
THE INFORMATION ON THIS DOCUMENT IS THE PROPERTY OF BHARAT HEAVY ELECTRICALS LTD. IT MUST NOT BE USED DIRECTLY OR INDIRECTLY IN ANY WAY DETRIMENTAL TO THE INTEREST OF THE COMPANY.

- NOTES :- 1) AFTER WELDING IT SHALL BE ENSURED THAT THE BUSHING IS VERTICAL AND TILT SHALL NOT BE MORE THAN 2 MM. SO THAT THE SPACING (230±2.0) IS MAINTAINED
 NOTE :- 2) ALL JOINTS SHALL BE TESTED AT 7 KG/CM² AIR PRESSURE FOR 60 SEC IN WATER TO DETECT LEAKS
 3) WELDING SHALL BE SMOOTH AND FREE FROM BLOW HOLES AND BURRS



002	BROWN GLAZE (M16 STUD)	002	17.5 KV BUSHING ASSY	4	3 614 04 00032	—	NA	KG	1.7
001	FOR 171 WIDTH	001	LID STN.STL.	3	3 614 02 00031	001	NA	KG	0.600
VAR 00	REMARKS	VAR	IT. NO.	DESCRIPTION	DRAWING NO.	NO.	MATL.CODE	UNIT	WT.
						VAR	MATL.SPEC.	C	QTY.

ADDITIONAL INFORMATION			TYPE OF PRODUCT OR NAME OF CUSTOMER/PROJECT N.E AGRA HVDC PROJECT								
STATUS OF DRAWING B			 BHARAT HEAVY ELECTRICALS LTD. BHOPAL				DRN	NAME P.K.PAUL	SIGN	DATE	NO.OF VAR
DISTRIBUTION OF PRINTS CPE-1 QC(TCB)-1 CPM-2 TRX(TCB)-1							CHD	T.SKARIAH			01
							APPD	M.KURRE			
REV	DATE	ALTERED	REV	DATE	ALTERED	DEPT CPE	SCALE	WEIGHT(kg)	REF TO ASSY DRG	ITEM NO.	NO.OF
		CHECKED			CHECKED	CODE 408	N.T.S	4			ITEM
		APPROVED			APPROVED						002
DRG. MODIFIED						TITLE : DOUBLE BUSHING LID ASSY. WITH 17.5 KV WELDABLE BUSHING			DRAWING NO. 3 614 02 00088		
						SHT NO.01			NO.OF SHT.01		

COMP.FILE NO.31402088

