

FIRST ANGLE PROJECTION (ALL DIMENSIONS ARE IN mm ) FORM DG 39(B)

REV	DATE	ALTERED	REV	DATE	ALTERED RAJPAL -sd-	GMS No./ C.B.O.M.- NO.		STATUS OF DRG U		
		CHECKED	02	20.12.11	CHECKED ASHISH SD/-	01050119000				
ZONE			ZONE	SUPERSEDES THE OLD DRG. UNDER THE SAME NO. CHANGE ADVISE NO. MTE-11-F0064			AGREED DEPT	NAME	SIGN	DATE
							STE	G.D.G.	-sd-	30.12.79
							STT	K.L.BALI	-sd-	17.12.79
GRADE OF UNTOL.DIM			M/CG. Q/M/R	-AA0230208	WELDING X/B/Q/D	AA0621104	GAS CUTTING-T3 AA0621101			

12.5 ALL OVER

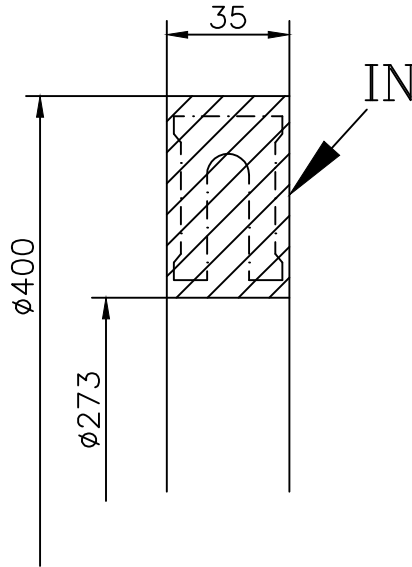

TECHNICAL REQUIREMENTS:-

1. FORGING SHALL BE SUPPLIED IN CONFORMITY WITH THE PURCHASING SPECIFICATION NO. HW19391.
2. TOLERANCES ON ALL DIMENSIONS : ±1mm.
3. THE SUPPLIER SHALL LOCATE THE POSITION OF THE TEST SAMPLE AND GET IT APPROVED FROM BHEL.PART OF TEST SAMPLE SHALL BE LEFT INTEGRAL FOR TESTING AT BHEL.
4. IDENTIFICATION MARKING SHALL BE DONE AT THE PLACE MARKED IN AS PER ST 00004. BY SUPPLIER PLANT.

COPYRIGHT AND CONFIDENTIAL

THE INFORMATION ON THIS DOCUMENT IS THE PROPERTY OF BHARAT HEAVY ELECTRICALS LIMITED. IT MUST NOT BE USED DIRECTLY OR INDIRECTLY IN ANY WAY DETERIMENTAL TO THE INTEREST OF THE COMPANY.

Gr.No.12106  
7280-12106/3  
Ref. Drawing No.

Sign & Date

Inventory No.



BHARAT HEAVY ELECTRICALS LTD.  
RANIPUR, HARDWAR

DRN	NAME	SIGN	DATE	NO. OF VAR
CBS	-sd-	7.12.79		
CHD	V.B.ARORA	-sd-	18.12.79	
APPD	A.K.MITHAL	-sd-	11.11.80	

DEPT	MTE		SCALE	WEIGHT (KG)	REF. TO ASSY. DRG.	ITEM No.	NO. OF ITEMS
CODE	4300		1:2	18.5	-	-	-
TITLE : FORGING FOR RING (ROUGH MACHINED)				CARD CODE	DRAWING NO. 41050119501		
					SHEET No. 01 No. OF SHEETS 01		

W95310514031  
HW19391

A4 SIZE