

FIRST ANGLE PROJECTION

(ALL DIMENSIONS ARE IN mm)

THE INFORMATION ON THIS DOCUMENT IS THE PROPERTY OF BHARAT HEAVY ELECTRICALS LIMITED
IT MUST NOT BE USED DIRECTLY OR INDIRECTLY IN ANY WAY DETRIMENTAL TO THE INTEREST OF THE COMPANY

| | | | | | | |
|-----------------|---------------|---------------------------------------|----------------------------|--------------|---|--|
| REV. 02 | DATE 19.11.04 | ALTERED CHECKED APPROVED H.R.P. | REV. 01 | DATE 7.12.2K | ALTERED Sd/- CHECKED Sd/- APPROVED Sd/- | ADDITIONAL INFORMATION |
| DRG. REDRAWN. | | | 12 DIGIT STYLE CODE ADDED. | | | STATUS OF DRAWING B |
| (DCA NO. 21514) | | | (DCA 10313) | | | DISTRIBUTION OF PRINTS □.C.-1 SWM-3 TCX-1 |

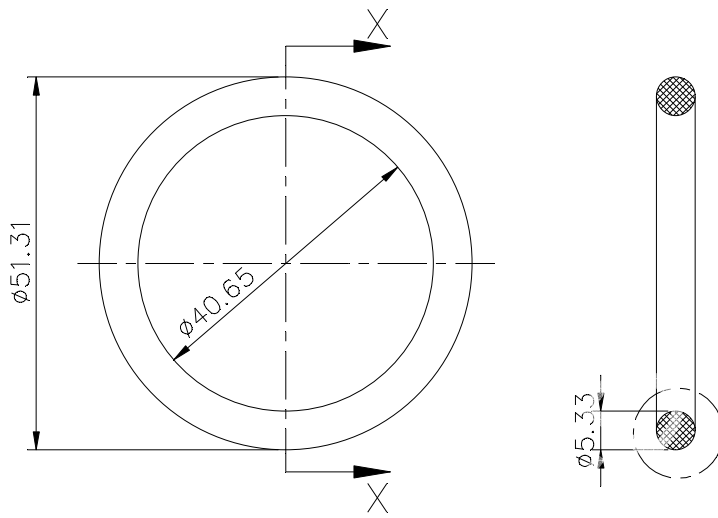

SECTION-XX

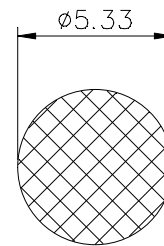

CROSS SECTION

NOTE: -

- 'O' RING DIMENSION AS PER SIZE 326 AND DIMENSION TOLERANCE AS PER IS 9975 PTI.

REF. DRG. NO.
SIGN. & DATE
INVENTORY NO.

| | | | | | | | | | | | | | |
|---------|----------------------|----|----|----|--------------|----|----|------------|----------|-------------|-------|----------|--|
| REMARKS | 75 | 25 | 27 | 29 | 58 | 59 | 46 | 54 | 55 | 56 | 68 | 71 | |
| | ITEM NO. | | | | DESCRIPTION | | | | UNIT | | QTY. | | |
| | FLAURO CARBON RUBBER | | | | BP9099330391 | | | | AA 59808 | | 0.016 | | |
| | | | | | | | | MATL. CODE | | MATL. SPCN. | | UNIT WT. | |

28 → CARD TYPE-3 28 → CARD TYPE-1 28 → CARD TYPE-2

| | | | | | | | |
|--|--|--|------------------|-------------------|----------------|----------------------------------|---|
| | भारत हेवी इलेक्ट्रीकल्स लिमिटेड भोपाल | | नाम NAME | हस्ताक्षर SIGN | दिनांक DATE | वे. री. की संख्या NO. OF VAR. | |
| | BHARAT HEAVY ELECTRICALS LTD. BHOPAL | | कनरा DRN | G.P. | Sd/- | 14.11.95 | - |
| | | | जीका CKD | D.P.K. | Sd/- | 14.11.95 | - |
| | | | अनुमोदित APPD | D.K.D. | Sd/- | 17.11.95 | - |

| | | | | | | | |
|-------------------|--|--|------------------------|---------------------------------------|---|----------------------------|---------------------------------|
| विभाग DEPT SWE | अन. टोल. नाप की श्रेणी UNTOI.DIMS. GR. M | | अनुपात SCALE 1:1 | भार कि.ग्रा. WEIGHT (K.G.) 0.30 | असेम्बली का संदर्भ REF. TO ASSY. DRG. 05171000501 | मद क्र. ITEM NO. 053 | मद संख्या NO. OF ITEM 001 |
|-------------------|--|--|------------------------|---------------------------------------|---|----------------------------|---------------------------------|

| | | | |
|---------------------|----------------------|---|----------------|
| शीर्षक/TITLE | 'O' RING (GVM-36) | आरेख क्र./DRAWING NO. 4 517 10 00560 | पुन/REV. 02 |
| पृष्ठ क्र./SHT. No. | 01 | पृष्ठों की संख्या/NO. OF SHT. | 01 |