

THE INFORMATION ON THIS DOCUMENT IS THE PROPERTY OF BHARAT HEAVY ELECTRICALS LIMITED IT MUST NOT BE USED DIRECTLY OR INDIRECTLY IN ANY WAY DETRIMENTAL TO THE INTEREST OF THE COMPANY

FIRST ANGLE PROJECTION (ALL DIMENSIONS ARE IN mm)

REV. 03	DATE 30.05.96	ALTERED Sd/-	REV. 01	DATE 31.08.83	ALTERED Sd/-	ADDITIONAL INFORMATION
		CHECKED Sd/-			CHECKED Sd/-	STATUS OF DRAWING B
		APPROVED Sd/-			APPROVED Sd/-	
MATL. SPECN ADDED.			LOAD CAPACITY & NOTES MODIFIED.			DISTRIBUTION OF PRINTS □C.-1 SWM-3 TCX-1
<DCA NO. 07766>						

REV. 03	DATE 27.09.03	ALTERED	
		CHECKED	
		APPROVED	
DRG. REDRAWN.			
<DCA NO. 12846>			

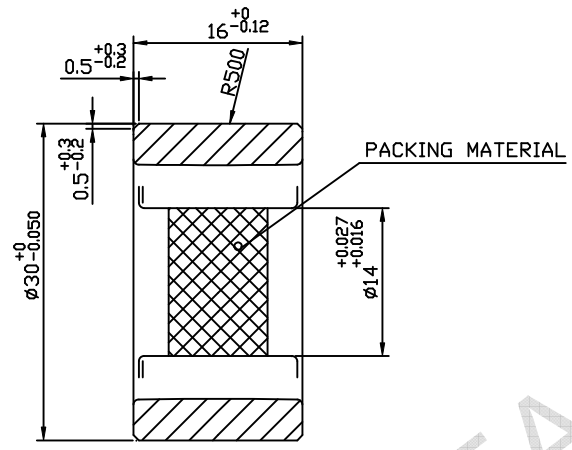

LOAD CAPACITY :-
 STATIC LOAD Cr = 1520 TO 1980 Kg.
 DYNAMIC LOAD CDr = 1680 TO 1840 Kg.

RADIAL LOAD FOR SUPPORT ROLLER :-
 CrW = 1250 TO 1470 Kg.
 CDrW = 1520 TO 1620 Kg.

NOTE :-

1. THE BEARING CONTAINS 23 NEEDLE ROLLERS OF $\phi 2.2 \times 15.8$ LG. TYPE G.2 OR 14 NEEDLES OF $\phi 4 \times 15.8$ LG. TYPE G-2.
2. THE BEARING SHALL BE GREASED WITH ROLLER BEARING GREASE AS PER DIN 51825.
3. THE BEARING IS EQUIVALENT OF NEEDLE ROLLER BEARING TYPE STUTZROLLE F-93747 RSTD 14x30x16 OF M/S INA, AND TYPE FAG 110-6217 OF M/S FAG KUGEL FISCHER.

BP9029432560	001	NEEDLE ROLLER BEARING	-	-	-
REMARKS	ITEM NO.	DESCRIPTION	MATL. CODE	UNIT WT.	QTY.
			SG 12720		

28 → CARD TYPE-3 28 → CARD TYPE-1 28 → CARD TYPE-2

	भारत हेवी इलेक्ट्रिकल्स लिमिटेड भोपाल		ड्राफ्ट्समैन C.H.U.	ड्राफ्ट्समैन Sd/-	ड्राफ्ट्समैन 07.12.82	ड्राफ्ट्समैन -
	BHARAT HEAVY ELECTRICALS LTD. BHOPAL		ड्राफ्ट्समैन M.Z.G.	ड्राफ्ट्समैन Sd/-	ड्राफ्ट्समैन 12.12.82	ड्राफ्ट्समैन -
			अनुमोदित BPN/RKG	ड्राफ्ट्समैन Sd/-	ड्राफ्ट्समैन 12.12.82	ड्राफ्ट्समैन -

विभाग DEPT SWE	अन. टॉल. माप की त्रुटि UNTOLE.DIMS. GR.	अनुपात SCALE	भार. वजन WEIGHT (KG.)	उत्प्रे. सं. का संदर्भ REF. TO ASSY. DRG.	सद. क्र. ITEM NO.	सद. संख्या NOL. OF ITEM
कोड CODE 409	AA0230208	2:1		35211001543	012	001
शीर्षक/TITLE				उत्प्रे. सं. /DRAWING NO.	पृष्ठ/REV.	
SUPPORT ROLLER				45211001622	03	
				पृष्ठ क्र./SHT. No. 01	पृष्ठों की संख्या/NO. OF SHT. 01	

51710\45171000532-R01-S01

446708 REF. DRG. NO. SIGN. & DATE INVENTORY NO.

RELEASED