

DRG NO 5046789

THE INFORMATION ON THIS DOCUMENT IS THE PROPERTY OF BHARAT HEAVY ELECTRICALS LIMITED. IT MUST NOT BE USED DIRECTLY OR INDIRECTLY IN ANY WAY DETRIMENTAL TO THE INTEREST OF THE COMPANY.

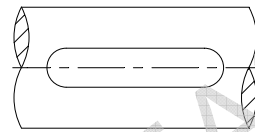
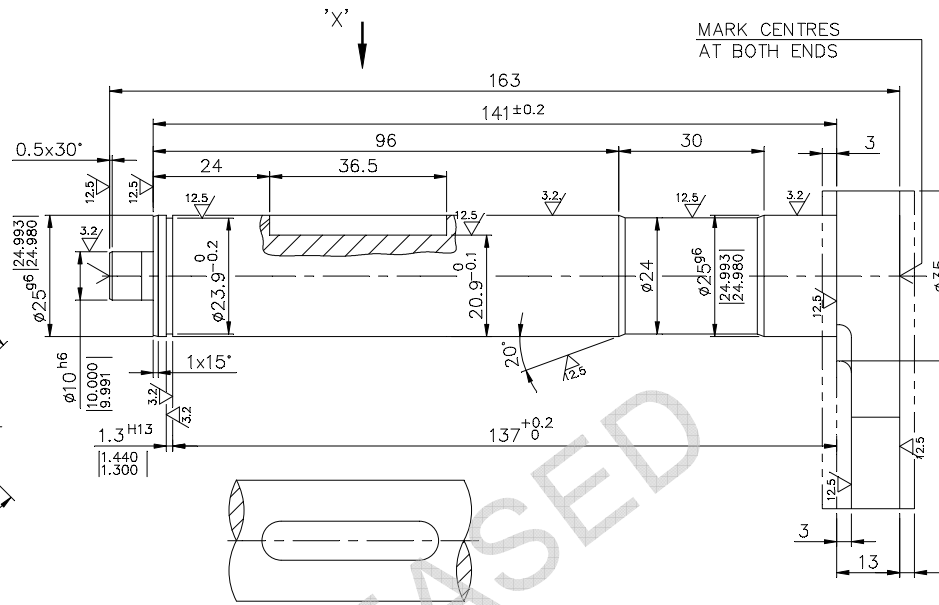
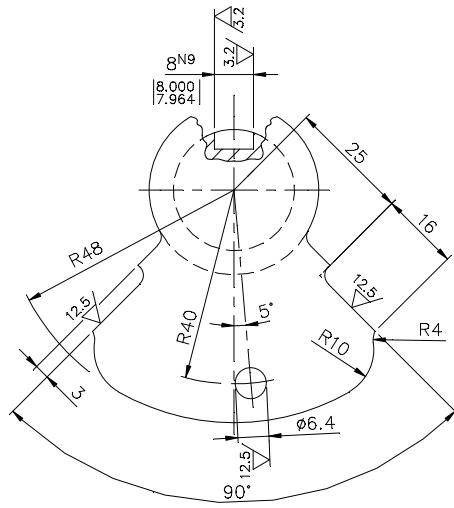

VIEW-X

MATERIAL SPECIFICATION	
ALLOY STEEL FORGING (20MnCr5)	
CHEMICAL COMPOSITION-	
CARBON	- 0.17 TO 0.22
MANGANESE	- 1.10 TO 1.40
SILICON	- 0.15 TO 0.40
CHROMIUM	- 1.00 TO 1.30
PHOSPHOROUS	- 0.035 MAX.
SULPHUR	- 0.035 MAX.
PROPERTIES-	
- IN NORMALISED CONDITION	
HARDNESS HB	- 217 (MAX.)
TENSILE STRENGTH-	(MIN.)-56Kg/mm ²
- AFTER MACHINING & HARDENING	
TENSILE STRENGTH-	100-140 Kg/mm ²
ENLOGATION	- (MIN.) 8%

- HARDEN & TEMPER HRC 30-35.
- APPLY TRP CASTROL-RUSTILO 630/HP-RUSTOP 285 FOR STORAGE.
- RADIUS NOT SHOWN=R2.5

PRE GRINDING DIM. FOR ϕ 24.993 TO BE ϕ 25.65
24.980 25.60

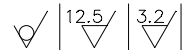

TOOL LIST		
ITEM	TOOL NO.	DESCRIPTION
-	1463690	COLLET
-	1463691	DRILL JIG
-	1463692	COPY MILLING FIXTURE
-	1463693	COPY MILLING TEMPLATE
-	1463098	GROOVING TOOL 1.3 H13
-	1463998	90°ANGLE PROFILE GAUGE 8 N9
-	1520092	SPLIT BUSH
-	1520293	SETTING PIECE ON SELF CENTRING VICE

VAR	ITEM NO.	DESCRIPTION	STD	DRAWING NO.	IT.ND.	MATERIAL CODE	A	UNIT	KG.
001	FORGING PART NO. 5257721	01 001 ALLOY STEEL FORGING				TO SPECN.			0.80
VAR 00	REMARKS	VAR ND. ITEM ND.			VAR	MATL. SPNC.	C	UNIT	QTY

ADDITIONAL INFORMATION				TYPE OF PRODUCT OR NAME OF CUST/PROJ		ON LOAD TAPCHANGER					
STATUS OF DRAWING				BHARAT HEAVY ELECTRICALS LIMITED		DRN	V.KUMAR	Sd/-	15.12.76	NO. OF VAR	
DISTRIBUTION OF PRINTS				BHOPAL		CKD	B.S.R.	Sd/-	19.12.76		
SWE SWM TCX				Bharat Heavy Electricals Limited		APPD	B.S.S.	Sd/-	20.12.76		
1	3	1		DEPT SWE	UN. TOL.DIMGR.	SCALE	WEIGHT (KG.)	REF TO ASSY	ITEM NO.	NO. OF ITEMS	
16	8.09.08	ALTD AKU CKD KS APPD SKP		409	M AA 0230208	1:1		5010335		001	
DRG. REDRAWN.				TITLE				DRG NO		REV.	
(D.C.A. NO. 21883)				DRIVE SHAFT				5046789		16	
								SHT.ND. 01	NO. OF SHT.	01	

5046789-R15-S01 REF.DRG.ND.

SIGN. & DATE

INVENTORY NO.