

THE INFORMATION ON THIS DOCUMENT IS THE PROPERTY OF BHARAT HEAVY ELECTRICALS LIMITED. IT MUST NOT BE USED DIRECTLY OR INDIRECTLY IN ANY WAY DETRIMENTAL TO THE INTEREST OF THE COMPANY.

5093325-R03-S01  
REF. DRG. NO.

SIGN. & DATE

INVENTORY NO.

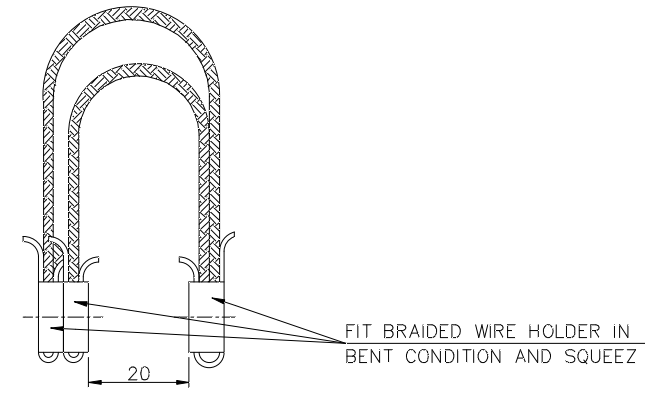
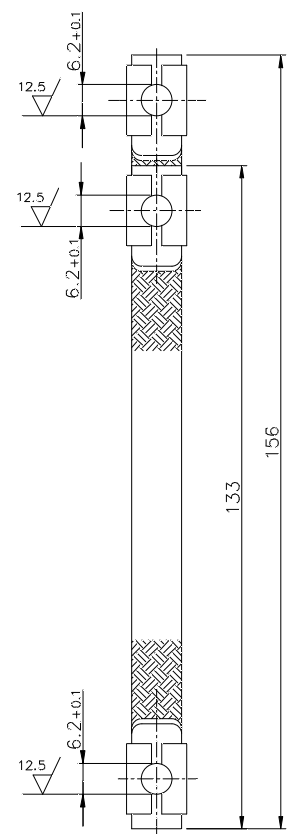
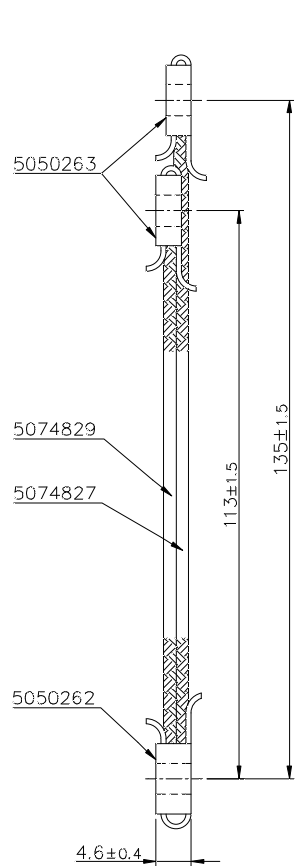

5093325 DRG NO

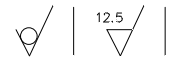

TOOL LIST		
ITEM	TOOL	DESCRIPTION
-	1463160	HOLDING FIXTURE
-	1520279	PRESS TOOL
-	1520799	30° DOVE TAIL BENDING TOOL
-	1520869	TOOL FOR INSERTING BRAIDED WIRE



M III 500/600

ADDITIONAL INFORMATION				TYPE OF PRODUCT OR NAME OF CUST./PROJ. <b>ON LOAD TAP CHANGER-M</b>								
STATUS OF DRAWING				 BHARAT HEAVY ELECTRICALS LIMITED BHPAL				NAME		SIGN	DATE	NO. OF VAR
DISTRIBUTION OF PRINTS								DRN	HEMANT	Sd/-	13.01.90	
SWE	SWM	TCX						CKD	I.J.S.	Sd/-	16.01.90	
				APPD	B.S.R.	Sd/-	02.02.90	00				
REV	DATE	ALTD	DEPT	SWE	UN. TOL. DIM. GR.	 SCALE 1:1	WEIGHT (KG)	REF TO ASSY		ITEM NO.	NO. OF ITEMS	
04		CKD	409	M	AA 0230208			5L12899, 5L17020				
DRAWING REDRAWN SLEEVE PART NOS. 5074831 & 5074833 DELETED DIM. 4.6±0.4 WAS 6-0.5 (DCA)				TITLE <b>BRAIDED WIRE SUB ASSEMBLY</b>				DRG NO <b>5093325</b>		REV. <b>04</b>		
							SHT. NO.	01	NO. OF SHT.	01		