

THE INFORMATION ON THIS DOCUMENT IS THE PROPERTY OF BHARAT HEAVY ELECTRICALS LIMITED. IT MUST NOT BE USED DIRECTLY OR INDIRECTLY IN ANY WAY DETRIMENTAL TO THE INTEREST OF THE COMPANY.

DRG NO 5670365

TOOL LIST		
ITEM	TOOL	DESCRIPTION
-	1463344	WELDING FIXTURE

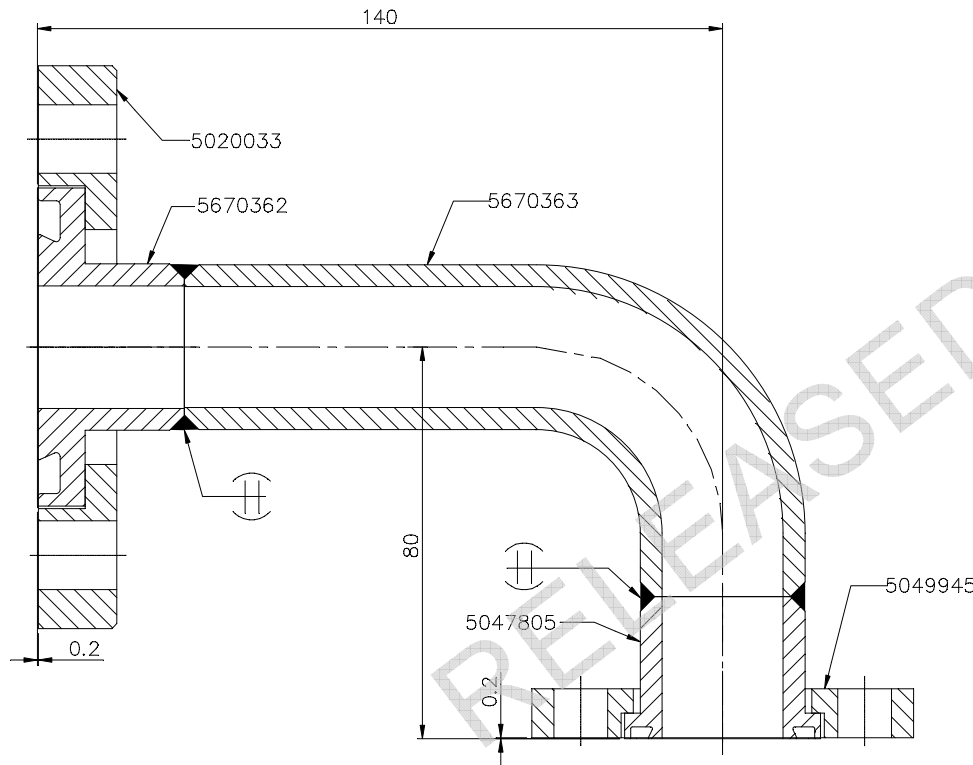

NOTE: -

- ALL WELDS TO BE GR.IV TO AA 062 21 01.
- PRESSURE TIGHT ACCORDING TO SG-13005.
- APPLY TRP CASTROL-RUSTILO 630/HP-RUSTOP 285 ON INSIDE & MACHINED SURFACES AND 2- COAT OF ANTI-CORROSIVE PRIMING PAINT AA56101 ON OUTSIDE FOR STORAGE.

5670365-R03-S01
REF.DRG.NO.

SIGN. & DATE

INVENTORY NO.

ADDITIONAL INFORMATION				TYPE OF PRODUCT OR NAME OF CUST/PROJ										
STATUS OF DRAWING				ON LOAD TAP CHANGER										
DISTRIBUTION OF PRINTS				BHARAT HEAVY ELECTRICALS LIMITED BHOPAL					NAME SIGN DATE NO. OF VAR					
SWE	SWM	TCX		DRN	AKU	sd/-	13.09.91							
1	3	1		CKD	IJS	sd/-	13.09.91							
				APPD	YUP	sd/-	21.09.91							
REV	DATE	ALTD	AKU	DEPT	UN. TOL.DIM.GR.	SCALE	WEIGHT (KG.)	REF TO ASSY	ITEM NO.	NO.OF ITEMS				
04	02.12.09	CKD	SKP	SWE	M	1:1		5086485	001	-				
		APPD	AKI	CODE	AA 0230208									
DRAWING REDRAWN				TITLE				DRG NO				REV.		
(DCA NO.-29394)				ELBOW SUB ASSEMBLY				5670365				04		
				SHT.NO. 01		NO. OF SHT.		01						