



CORPORATE PURCHASING SPECIFICATION

AA 28127

REV NO. 06

PAGE 1 OF 10

PAPER COVERED CONTINUOUSLY TRANSPOSED COPPER CABLE

1.0 GENERAL:

This specification governs the quality requirements of a paper covered continuously transposed copper conductor (CTC) incorporating a number of individual annealed copper strips insulated with a polyvinyl - acetal based enamel of fine grade and covered over all with not less than three layers of paper and suitable for use in hot insulated oil . Paper shall conform to BHEL Corporate Purchase Specification (CPS) No. AA 21111 or AA 21116.

The material in insulating oil shall have a temperature index of 105.

2.0 APPLICATION:

Used for windings of Transformers.

3.0 COMPLIANCE WITH NATIONAL STANDARDS:

There is no Indian Standard covering this type of material. However assistance has been taken from the following specifications. î

IS :13730 Pt.17- 1996/ : Specification for particular type of Winding Wires î
IEC : 60317-17- 1990/ Pt..17 Polyvinyl Acetal enameled, Rectangular
Copper Wire-class 105.

IS : 13730 PT.27 - 1996/ : Specification for particular type of winding wires î
IEC : 60317-27 - 1990 Pt . 27 Paper covered Rectangular copper Wire.

4.0 TEST SAMPLES :

4.1 Paper :

The supplier shall send test certificates for papers for all the tests as per BHEL Corporate Purchasing Specification (CPS) No. AA 21111 or AA 21116 for our approval. The test report shall be sent for each lot of paper and of different thickness received from the paper mill, which are to be used in the manufacture of BHEL paper covered continuously transposed copper cable.

In the absence of proper test certificate 20 sheets of size 300 x 300 mm of paper from each lot & of different thicknesses shall be supplied for our testing & approval.

Revision :

C I . 34.1.19 of MOM of MRC (E)

APPROVED :

INTER PLANT MATERIAL
RATIONALISATION COMMITTEE- MRC (E)

Rev.No. 06

Dt. 14-05-2007

Amd.No.

Dt.

Reaffirmed

Year

Prepared
BHOPAL

Issued
Corp. R&D

Dt.of Ist Issue
Aug . 1980

COPYRIGHT AND CONFIDENTIAL
The information on this document is the property of Bharat Heavy Electricals Limited .
It must not be used directly or indirectly in any way detrimental to be interest of the company



CORPORATE PURCHASING SPECIFICATION

AA 28127

REV NO. 06

PAGE 2 OF 10

4.2 Finished Cable:

3 metre long sample of CTC shall be supplied for testing and inspection.

5.0 CONDUCTOR:

5.1 CTC of any size given in Transformer standard sheets shall be ordered. Maximum and minimum dimensions of bare cable shall be as per these individual orders. Conductor size, No. of parallels and radial paper covering shall be stated on the order.

5.2 Radial insulation shall be from 0.20 to 3.0 mm, both inclusive.

5.3 Bunched CTC consisting of 2 or more individual stacks of any size indicated in Transformer Standard sheets shall also be ordered whenever required.

6.0 LENGTH & WEIGHT OF CABLE:

6.1 The total weight of cable, the length of cable per drum and the total No. of drums shall be as stated on the order. Length of cable per drum specified in our order is very important and it shall neither be less nor more than the specified.

6.2 Weights indicated in our orders are nominal and can vary within ± 2 percent considering allowed tolerances on dimensions and on corner radius.

Excess weights more than 2 percent shall not be admissible under any circumstances.

7.0 TYPE OF ENAMEL COVERING:

Fine grade. However in exceptional cases when medium grade of covering is required, it shall be stated on the order.

8.0 CONDUCTOR:

8.1 Grade of Material:

The conductor shall be manufactured from ETP grade copper conforming to BHEL Corporate Purchasing specification AA 12024.

Note : Manufacture of the Copper conductors from continuous cast copper bars is preferable provided all other acceptance parameters and conditions remains same.

The elongation of the conductor after removal of paper shall be as given below. Test shall be carried out on these samples with gauge length of 200 mm.



CORPORATE PURCHASING SPECIFICATION

AA 281 27

REV NO. 06

PAGE 3 OF 10

| Nominal conductor thickness, mm | | Elongation % |
|---------------------------------|-------------------|--------------|
| Over | Up to & including | minimum |
| - | 2.5 | 30 |
| 2.5 | 5.6 | 32 |

8.2 Electrical Resistivity :

The electrical resistivity at 20 Deg.C, when measured directly on the sample in "as received" condition shall not be greater than $0.01739 \text{ ohm} / \text{mm}^2 / \text{m}$ (Refer appendix 'B' of IS:613 for temperature correction factor).

8.3 Enameled Conductor :

↑

The enameled conductor shall comply with fine grade of covering to IS 13730 Pt. 17 : 1996 with the exceptions as given below :

8.4 Joints:

8.4.1 Joint in bare conductor:

Joints shall not be made in the conductor after it is drawn. Any joint made during the drawing process shall be resistance welded.

8.4.2 Joint in enamelled conductor:

If a joint in the enamelled conductor becomes unavoidable due to breakage, accidental stoppage of machine or when the specified length is in excess of the capacity of transposing machine bobbins, it shall be made by resistance welding, care being taken to ensure that the joint is made sound.

All surplus weld shall be removed by filing and the joint finished with emery cloth to give a smooth clean surface after which it shall be patch enameled. Any joint shall be insulated from the adjacent strips by a single piece of 100 um thick paper half over lapped. Joints in the individual strips shall be staggered so that the distance between individual joints along the cable shall not be less than 150 mm. A red tag shall be tied at the jointed portion of cable for identification and inspection. Any such joint shall be made only after prior approval of BHEL.

9.0 PAPER:

9.1 Grade of Paper :

Kraft paper shall conform to BHEL Corporate Purchasing specification (CPS) No. AA 21111 or AA 21116. If kraft / manila mixture or any other paper is used, it shall conform to BHEL Corporate Purchasing Specification (CPS) No. AA 41111 or AA21116.



9.2 Thickness:

The thickness of paper shall be within limits of 50 and 125 um both inclusive.

10. CONSTRUCTION OF TRANSPOSED CABLE:

10.1 Cleanliness of Enameled Conductor:

The enameled conductor shall be free from copper dust and other extraneous matter prior to transposing and covering with paper.

10.2 Transposition of Enameled Conductor:

The cable shall be manufactured from any odd number of enameled conductors from a minimum of 5 to a maximum of 31, according to the size of the individual conductor and the overall size of the cable as specified in the order.

The cable shall be formed by placing the strips into two stacks, the stacks, being edge to edge and the whole group of strips being continuously transposed along the length of the cable.

The pitch of successive transpositions shall be approximately 15 times the width of bare strip subject to a minimum of 50 mm. Lay i.e. the distance over which a strip resumes its original position in the conductor shall be equal to pitch multiplied by the number of strips.

For cables of radial depth 10 mm and above it shall have an inter column paper (paper spacer) inserted between the vertical stacks of strip. This paper shall comply with clause 9 and thickness shall be 100 um. Width of the paper spacers shall not be less than the value calculated from the following formula.

$$\text{Width} = \frac{(\text{Number of strips} - 1)}{2} \times \text{thickness of enameled strip}$$

10.3 Application of Paper Covering:

10.3.1 General:

Each layer of paper shall be continuous, firmly applied and substantially free from creases. No bonding or adhesive material shall be used except to anchor the ends of paper. Any such bonding or adhesive material shall have no deleterious effect on transformer oil, insulating paper, or electric strength of the covering. When papers of different thickness are used, the outermost paper shall be the thickest. The thickness of the paper shall be progressively increased from the innermost to the outermost layer.



CORPORATE PURCHASING SPECIFICATION

AA 281 27

REV NO. 06

PAGE 5 OF 10

10.3.2 Width of paper :

The width of paper shall be within the limits of 15 and 40 mm, both inclusive.

10.3.3 Arrangement of layers:

All the layers shall be applied in the same direction, all except the two outermost layers shall be butt wound and the two outermost layers shall be applied together with a staggering of 50% so that they are interlocked giving 50% overlap effect. Within each group the positions of the butt joints of any layer relative to the layer below shall be progressively displaced by approximately 30 percent of the paper width. There shall not be any gap between edges of adjacent turns of first butt wound paper layer i.e. enameled copper should not be visible. In subsequent butt wound layers, a possible gap of 0.5 mm maximum and overlap up to 1 mm between edges of adjacent turns shall be allowed.

10.3.4 Paper thickness for butt and overlap interlocked would layers:

Thickness of paper for butt wound layers shall be between 50 um and 100 um (both inclusive). Two outermost overlap interlocked layers shall be wound with paper of thickness between 75 and 125 microns (both inclusive). However, when radial insulation is 2.2 mm or more, 140 um paper for two outermost layers is allowed to avoid two paper covering operations due to availability of a maximum of 24 paper heads in the lapping machine of same manufactures. Special extensible high density and high mechanical strength paper meeting the requirements of clause 9 can be used in the two outermost interlocked layers.

10.3.5 Wax Coating :

When specified on order, a coating of paraffin wax to IS:4654 of thickness not exceeding 0.02 mm shall be applied on the bottom flat sides of fully paper covered width of the conductor

11. DIMENSIONS OF TRANSPOSED CABLES :

11.1 Method of Calculating Maximum Bare Axial Width (AW) :

$AW = 2(b + e) + F$ + inter column paper if specified (100 µm thick)

Where :

AW = Max. bare axial width of transposed cable.

b = Maximum axial width of bare individual conductor
= Nominal width + Tolerance (from table 1 below)

e = Maximum increase in dimension due to enameling
(as per IS : 13730 Pt. 0 /Sec. 2 : 1993 (R2003), IEC 60317-0-2:2005)
= 0.11 mm for fine grades of covering

F = Free space allowance = 0.2 mm



CORPORATE PURCHASING SPECIFICATION

AA 281 27

REV NO. 06

PAGE 6 OF 10

Table 1 - Tolerance on Nominal Dimensions - (IS : 13730 Pt. 27 - 1996)

| Dimension (Width or Thickness),mm Over | Up to and including | Tolerance ± mm |
|---|---------------------|----------------|
| - | 3.15 | 0.030 |
| 3.15 | 6.30 | 0.050 |
| 6.30 | 12.50 | 0.070 |
| 12.50 | 16.00 | 0.100 |

11.2 Method of Calculating Max. Bare Radial Depth (RD) :

$$RD = \frac{N + 1}{2} (T + e) + \text{Free space allowance (from Table 2)}$$

Where

RD = Max. bare radial depth of Transposed Cable.

T = Maximum thickness of bare individual conductor
= Nominal thickness + Tolerance (from table 1, in cl. 11.1)

N = Number of conductors in parallel

e = Maximum increase in dimensions due to enameling
(as per IS : 13730 Pt.0/Sec 2 : 1993 (R 2003), IEC 60317-0-2 : 2005)
= 0.11 mm for fine grade of covering.

TABLE 2 - FREE SPACE ALLOWANCE - RADIAL DEPTH (mm)

| No. of conductors | Free space allowance radial depth, mm | |
|----------------------|---------------------------------------|--------------------------|
| | Thickness 1 -- 2 mm | Thickness 2.1 -- 3.15 mm |
| 5-11 | 0.25 | 0.55 |
| 13 | 0.28 | 0.60 |
| 15 | 0.30 | 0.68 |
| 17 | 0.33 | 0.75 |
| 19 | 0.35 | 0.80 |
| 21 | 0.38 | 0.85 |
| 23 | 0.40 | 0.90 |
| 25 | 0.45 | 1.00 |
| 27 | 0.50 | 1.10 |
| 29 | 0.55 | 1.20 |
| 31 | 0.60 | 1.30 |



11.3 Method of Calculating Maximum Axial Width & Radial Depth with Paper Covering:

Maximum covered Axial Width = $AW + t$

Maximum covered Radial Depth = $RD + t$

Where AW is taken from Clause 11.1

RD is taken from Clause 11.2

t = nominal increase in dimensions due to paper covering taken from Cl. 11.4.

11.4 Increase in Dimensions due to paper covering:

11.4.1 Increase in Dimensions:

The increase in dimensions due to covering shall have tolerance indicated below:

| Increase due to covering , mm | | Tolerance % |
|-------------------------------|-------------------|-------------|
| Over | Up to & including | |
| - | 0.5 | + 0 - 10 |
| 0.5 | 1.3 | + 0 - 7.5 |
| 1.3 | - | + 0 - 5 |

11.4.2 Measuring Equipment:

The measurement shall be made with a suitable ratchet micrometer . The spindle and anvil of the micrometer shall have a diameter of 5 to 8 mm.

11.4.3 Measuring Method:

"Covered Dimension" shall be measured at three positions not less than 100 mm apart. . The measurements shall be made on completely straight parts of the transposed cable. The measurement shall include at least one over lap. The average of three results shall be reported as "Covered Dimensions". The covering shall be removed by any method which does not damage the conductor for three positions used for the measurement of "Covered Dimensions" and "Bare Dimensions" measured at these positions. The average of the three results shall be reported as "Bare Dimension". The difference between "Covered Dimension" and the "Bare Dimension" shall be reported as the increase in dimension due to covering.

11.4.4 Counter Check:

The increase in dimension due to covering shall also be counter checked by adding up the thickness of paper used in each layer. The thickness of paper shall be measured by dead weight micrometer conforming to IS: 1060 (Part 1) by stacking the tapes of paper one above the other. Paper tape shall not be folded to form two or more tapes. Length of paper tapes shall not be less than 150 mm. Five measurements shall be made distributed over the stack. The paper thickness shall be computed by dividing by five the mean of five readings.



12.0 TESTS ON FINISHED CABLES:

12.1 Insulation Test

The insulation test at 250 V,AC for 1 minute shall be conducted on all drums between each and every other strip in CTC stack. There shall be no fault in the insulation. In case of bunched (twin) CTC, this test shall also be conducted between two stacks.

13. TEST CERTIFICATE:

Unless otherwise stated three copies of the test certificates shall be supplied along with each consignment,

In additional the supplier shall ensured to enclose one copy of test certificate along with their dispatch documents to ensure quick clearance of the material.

The test certificate shall bear the following information

AA 28127 : Paper covered continuously Transposed Copper Cable.
(Rev. 06)

Covered & Bare Dimension of cable, No. and size of individual conductor, increase In dimensions due to paper covering, number of paper layers and thickness of paper in each layer, grade of enamel and length of cable shall be indicated in the test certificate.

BHEL Order No.
Manufacturer's / Supplier's name
Trade mark, if any
Batch No./Lot No.

Test results of clauses 5 & 8 to 12.

Test certificate for compliance of characteristics of paper to BHEL Corporate Purchasing Specification (CPS) No. AA 21111 and AA 21116.

14. PACKING AND MARKING:

The transposed cable shall be tightly and evenly wound, without twist, on drums in such a direction that when unrolled the exposed edge of the overlap of the outer layer of paper is towards the drum. The size of drum shall be selected from Annexure I. Drum flanges shall have an arrow mark showing the position of finishing end of cable.

Barrel dia 'C' for drum shall be at least 50 times of covered radial depth of cable subject to a maximum of 900 mm (Barrel 14) When specified on order, drums of barrel dia 1070 & 1140 mm shall be used. Out side flange dia A of drums can be reduced by the supplier considering the packing weight of CTC and capacity of the drum. How ever, it shall be ensured that cable is not packed up to the brim of the drum.



CORPORATE PURCHASING SPECIFICATION

AA 281 27

REV NO. 06

PAGE 9 OF 10

Before winding the insulated strip, a layer of polythene sheet or similar waterproof material shall be wrapped on empty drum. After winding the cable, the sheet edges shall be folded over the cable and then a polythene strip shall be wound on outside.

As a final protection, a layer of oiled canvas or similar waterproof material shall be wrapped over the polythene sheet, ensuring that no part of the cable is exposed.

Drums used for packing shall be made from seasoned wood. Circular disc separator shall be made from plywood.

Metal / Non –Metal straps used over, the drum shall be stamped/sealed with the manufacturer's identification marks. Similarly, end of the conductor shall also be stamped/sealed.

Each drum shall be labeled clearly stating the following information. The label shall preferably be cemented into a recess in the side of the flange of the drum. ↑

AA 28127 - Paper Covered continuously Transposed Copper Cable. ↑

BHEL Order No.
Manufacturer's Name / Suppliers Name

Maximum covered and bare dimension of cable, No. and size of individual conductor, increase in dimensions due to paper covering, No. of paper layers and thickness of paper in each layer, grade of enamel and length of cable.

Batch No./Lot No..

Net weight / Gross weight.

15. REFERRED STANDARDS (Latest Publication Including Amendments) : ↑

- | | | | |
|-------------|----------------------|-----------------|-------------------|
| 1. AA 21111 | 2. AA 21116 | 3. AA 12024 | 4. IS : 13730-17 |
| 5. IS:4654 | 6. IS : 613 | 7. IEC 60317-17 | 8. IEC : 60317-27 |
| 9. IS:1060 | 10. IS : 13730 Pt.27 | | |



ANNEXURE - I

Dimensions of Standard Drum

| DIMENSION | | Drum Designation | | | | | | |
|-----------------------------|---|------------------|-----|------|------|------|------|------|
| | | 8 | 9 | 10 | 14A | 14B | 14C | 14D |
| Outside Flange diameter | A | 800 | 900 | 1000 | 1400 | 1400 | 1400 | 1400 |
| Barrel dia | C | 600 | 600 | 700 | 900 | 900 | 900 | 900 |
| Overall width | D | 440 | 440 | 660 | 440 | 710 | 910 | 580 |
| Traverse | B | 340 | 340 | 560 | 340 | 610 | 810 | 480 |
| PCD of Driving Holes | J | 300 | 300 | 600 | 600 | 600 | 600 | 600 |
| Flange depth | G | 88 | 138 | 138 | 238 | 238 | 238 | 238 |
| Approximate Capacity in Kg. | | 300 | 480 | 890 | 1230 | 2200 | 2900 | 1730 |

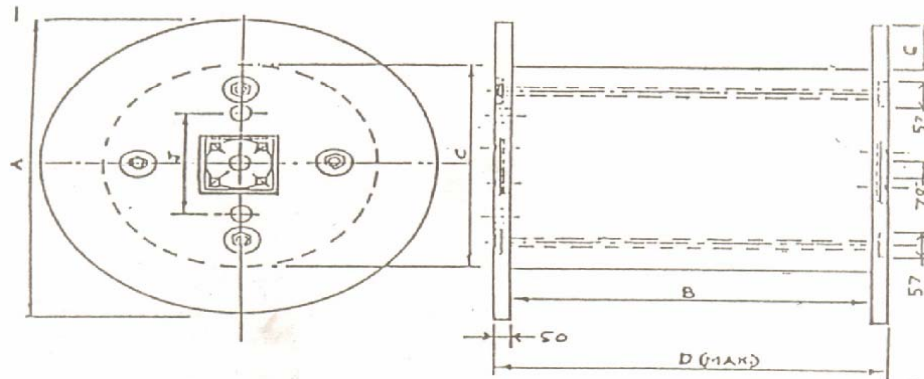

- NOTE:**
- Partitions to hold multiple length in a drum shall be of 12.5 mm thick.
 - Any fixing bolt used within a circle of 600 mm diameter shall not project outside flange surface.

Note:

- Partitions to hold multiple length in a drum shall be of 12.5 mm thick.
- Any fixing bolt used within a circle of 600 mm diameter shall not project outside flange surface.