

FIRST ANGLE PROJECTION

(ALL DIMENSIONS ARE IN mm)

DRG. NO. 3 439 20 00 006

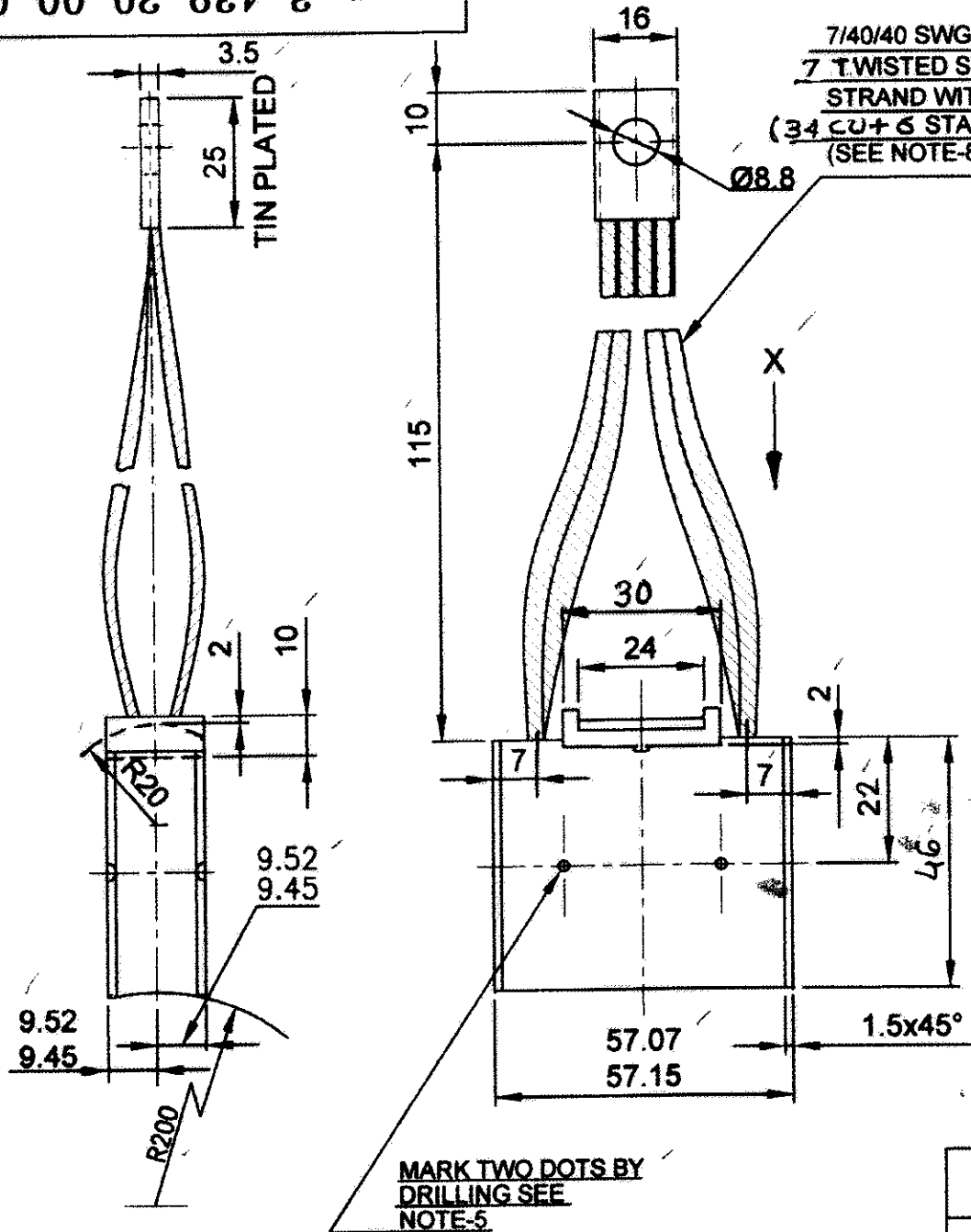

7/40/40 SWG (0.122MM DIA)
7 TWISTED STRANDS EACH
STRAND WITH 40 WIRES OF 40 SWG
(34 CU + 6 STAINLESS STEEL)
(SEE NOTE-8)

SILICONE RUBBER TOP TO BE BONDED
WITH SUITABLE ADHESIVE.

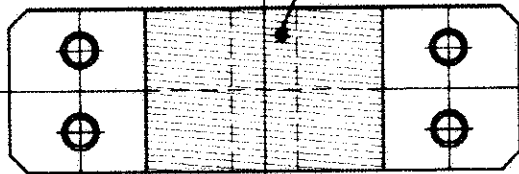

MARK TWO DOTS BY
DRILLING SEE
NOTE-5

STYLE LIST		
VAR.	IT.NO.	DESCRIPTION
-	001	BP9044750364

NOTES:-

- CARBON BRUSH GRADE MORGAN EG-14D OR CARBON-EG6754-
- TECHNICAL DATA OF BRUSH GRADE VIZ APPARANT DENSITY, SHORE HARDNESS, TRANSVERSE STRENGTH, SPECIFIC RESISTANCE, CONTACT VOLTAGE DROP, CO-EFFICIENT OF FRICTION AND MATERIAL DETAILS OF RUBBER TOP ARE TO BE SUPPLIED ALONG WITH QUOTATION TO ENABLE CONSIDERATION OF THE OFFER.
- CARBON BRUSH SHALL CONFORM TO IS 13466 & 13584 OTHERWISE STATED.
- BRUSH GRADE AND MANUFACTURERS NAME/TRADE MARK SHALL BE ENGRAVED ON BOTH THE WIDER FACES ABOVE THE CONDEMNING MARK.
- CONDEMNING MARK SHALL BE MADE ON TWO WIDER FACES
- REFER TM 98262 FOR ACCEPTANCE OF CARBON BRUSH.
- ALTERNATIVE BRUSH GRADE EG 6754 (IMPORTED)
- ALTERNATIVELY FLEXIBLE CAN BE OF SIZE 7x56 (48CU+8SS)x40SWG.
- THE GRADES OF CARBON BRUSHES SHALL BE AS PER LATEST RDSO APPROVED LIST. CURRENT RDSO APPROVED LIST TO BE ESSENTIALLY REFERRED BEFORE PI / ENQUIRY.

VAR. OR	REMARKS	VAR. NO.	ITEM NO.	DESCRIPTION	STD.	DRAWING NO.	IT. NO.	MATL. CODE	A/C	UNIT	UNIT WT.	G.S.	ZONE
	SEE NOTE 3&6 B.O.		001	SPLIT CARBON BRUSH						kg	0.100		

ADDITIONAL INFORMATION

TYPE OF PRODUCT OR NAME OF CUSTOMER/PROJECT **165/M RLY MOTOR & TM 4906AZ/BZ TM 4907 AZ**

STATUS OF DRAWING

DISTRIBUTION OF PRINTS

TME-1
TNX-1
TXM-3



BHARAT HEAVY ELECTRICALS LTD.
BHOPAL

DRN	NAME	SIGN	DATE	NO. OF
	C.KSB	Sd	6.3.87	
	KDG	Sd	6.3.87	
	KDG	Sd	6.3.87	

REV.	DATE	ALTERED	CHECKED	APPROVED
14	01/06/11			

REV.	DATE	ALTERED	CHECKED	APPROVED
13	22.5.09	K	M-L	

DEPT	GRADE OF UN.TOL. DIM	SCALE	WEIGHT (K.G.)	REF. TO ASSY. DRG.	ITEM NO.	NO. OF ITEM
TME		NTS	0.100	0 439 20 00 001	010	001

DIM. 22, 46 WERE
28, 52.

DRAWING UPDATED & DIGITIZED

SPLIT CARBON BRUSH

DRAWING NO. **3 439 20 00 006** 14

SHT. No. 01 NO. OF SHT. 01

IT MUST NOT BE USED DIRECTLY OR INDIRECTLY IN ANY WAY DETRIMENTAL TO THE INTEREST OF THE COMPANY

INVENTORY NO. SIGN. & DATE REF. DRG. NO.