

THE INFORMATION ON THIS DOCUMENT IS THE PROPERTY OF BHARAT HEAVY ELECTRICALS LIMITED. IT MUST NOT BE USED DIRECTLY OR INDIRECTLY IN ANY WAY DETRIMENTAL TO THE INTEREST OF THE COMPANY.

INVENTORY NO. SIGN. & DATE REF. DRG. NO.

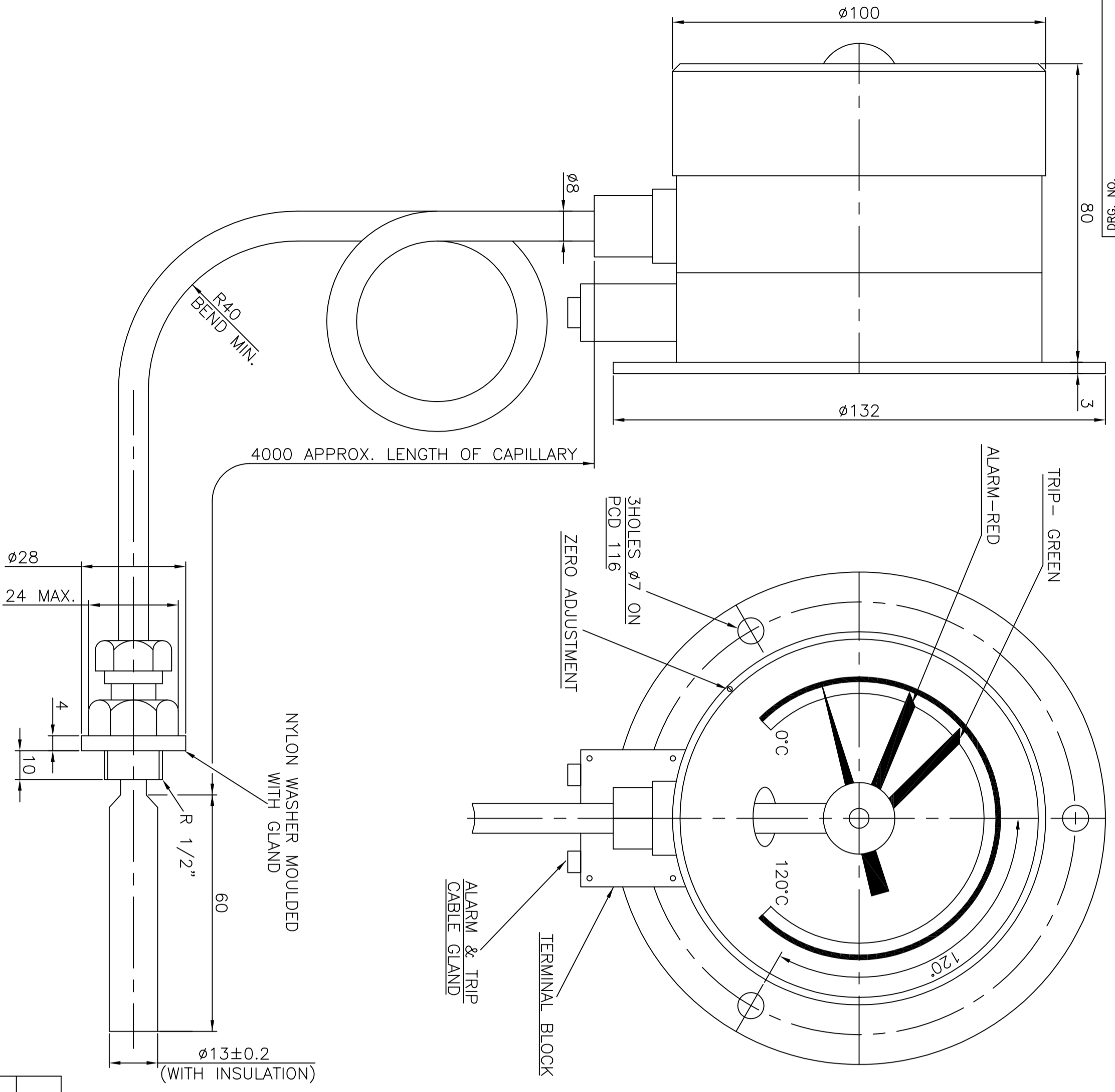

TECH. REQUIREMENTS:-

1. DIAL - 100mm WHITE DIAL WITH BLACK NUMERALS, SCALE TO BE SPREAD OVER 270° CIRCUMFERENCE.
2. SENSING ELEMENT - MERCURY IN STEEL.
3. RANGE - 0° TO 120° (WITH GRADUATION AT 1°C INTERVAL)
4. ACCURACY - ±2°C
5. MATERIALS - a) CASING - ALUMINIUM
 b) CAPILLARY - MILD STEEL/BRASS (FLEXIBLE) / PVC/TEFLON COVERD CAPILLARY.
6. POINTERS
 a) OF ACTUAL VALUE - BLACK COLOUR.
 b) OF FIRST CONTACT - RED COLOUR.
 c) OF SECOND CONTACT - GREEN COLOUR.
7. CABLE ENTRY CONNECTION - R-1/2" BOTTOM ENTRY.
 THE POINTERS FOR CONTACTS ARE TO BE EXTERNALLY ADJUSTABLE. THE KEY FOR ADJUSTMENTS TO BE SUPPLIED ALONGWITH EACH THERMOMETER.
8. CONTACT - TWO CONTACTS INDEPENDENTLY ADJUSTABLE OVER FULL RANGE OF OPERATION AS ILLUSTRATED IN THE SKETCH, WITH CONTACT RATING : 5A AT 240 V AC AND 0.5 A AT 220 V DC.
9. TESTING - INSULATION TO BE TESTED AT 1.5 KV FOR 60 SECONDS.
10. GENERAL CONSTRUCTION - BLACK FLANGE (WALL MOUNTED) WEATHER PROOF WITH NON-GLARE GLASS FRONT SUITABLE FOR OUTDOOR. APPLICATION, WITHOUT ADDITIONAL PROTECTION. THE CAPILLARY SHALL HAVE A SLIDING GLAND ALONG WITH COMPRESSION TYPE SLEEVE TO GRIP THE CAPILLARY. THE THERMOMETER SHALL BE INSULATED AGAINST ITS MOUNTING FOR WHICH BULB SHALL BE INSULATED.
11. TEST - THE THERMOMETER SHALL PASS THE TEST AS PER BHEL CORPORATE STANDARD AA0851410.

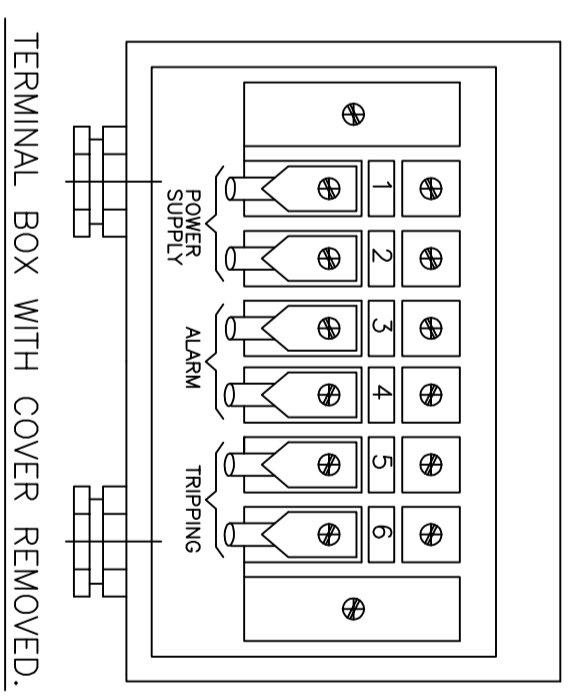

TERMINAL BOX WITH COVER REMOVED.

REV	DATE	ALTERED BY	CHECKED BY	APPROVED BY	ZONE	DESCRIPTION	DRAWING NO.	MATL. CODE	MATL. SPON.	UNIT WT.	NO. OF ITEMS
08	4.6.13	VAIBHAV	VAIBHAV	TR.11		DIAL TYPE THERMOMETER WITH BULB Ø13mm	BP9035027860				
VAR 00											

ADDITION INFORMATION		TYPE OF PRODUCT	
STATUS OF DRAWING		OR	
DISTRIBUTION OF PRINT		NAME OF CUSTOMER/PROJECT	
OC-1		BHARAT HEAVY ELECTRICALS LTD.	
PLM-3		BHOPAL	
TEX(PLM)-1			

REV	DATE	ALTERED BY	CHECKED BY	APPROVED BY	ZONE	DESCRIPTION	DRAWING NO.	MATL. CODE	MATL. SPON.	UNIT WT.	NO. OF ITEMS
08	4.6.13	VAIBHAV	VAIBHAV	TR.11		DIAL TYPE THERMOMETER WITH TWO CONTACTS	24021040136				