

15219002508
IN ENGLISH

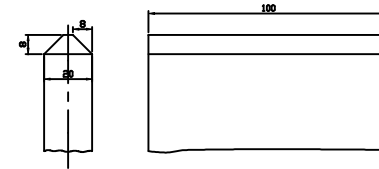

SKETCH 'X'

NOTE:-
1. SHUTTER OPERATION SHOULD BE CHECKED WITH A TEST FINGER AS PER SKETCH 'X' BY INSERTING AND WITHDRAWING IT CENTRALLY.

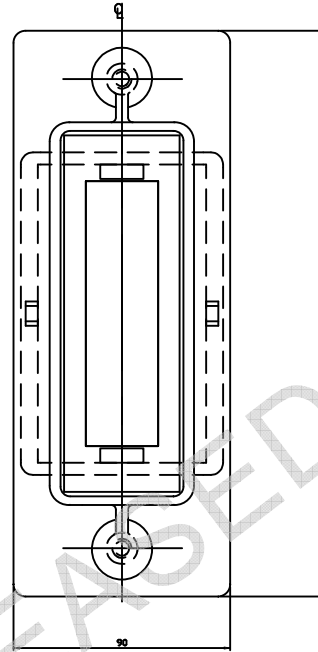
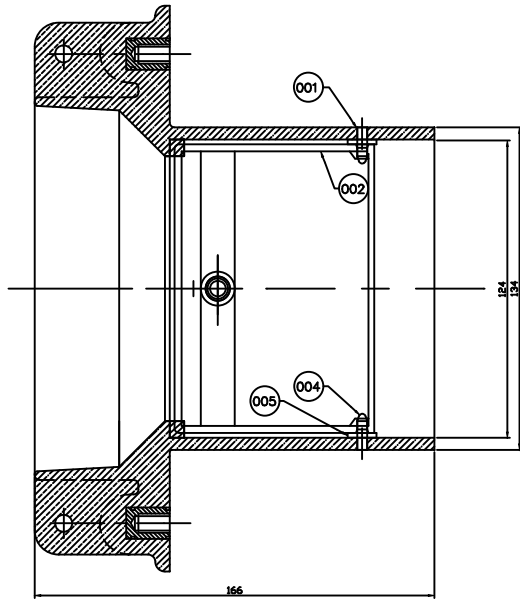
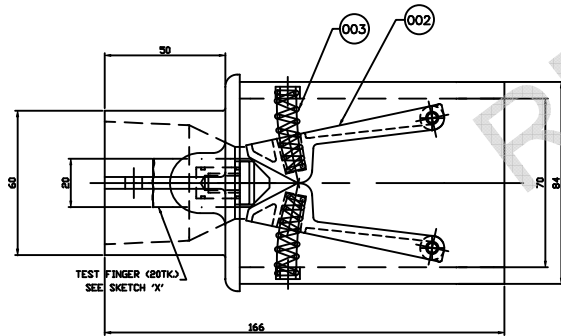

SHUTTER CLOSED POSITION

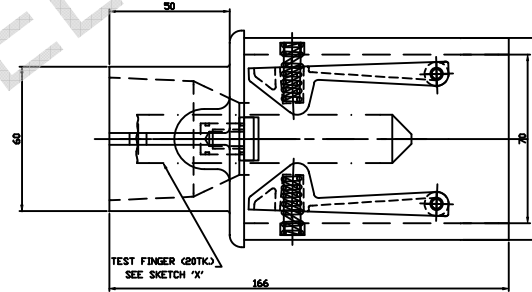

SHUTTER OPEN POSITION

THE INFORMATION ON THIS DRAWING IS THE PROPERTY OF BHARAT HEAVY ELECTRICALS LIMITED. IT MUST NOT BE USED DIRECTLY OR INDIRECTLY, IN ANY MANNER, WITHOUT THE WRITTEN PERMISSION OF THE COMPANY.

15219002508-001-001

ITEM NO	ITEM NO	DESCRIPTION	QTY	DRAWING NO	ITEM NO	ITEM NO	ITEM NO	ITEM NO	ITEM NO
008	005	NYLON WASHER 2TK X 5 1/2 x 10 O/D	-						001
004	004	FIN PA.2 x 16LG. ACRYLIC			AA22820				001
002	003	SPRING	45216001528	001					001
002	002	SHUTTER FLAP	35219002529	001					001
001	001	SHUTTER BODY	15219002507	001					001
VAR.08	REMARKS	VAR NO	ITEM NO	DESCRIPTION	QTY	DRAWING NO	ITEM NO	ITEM NO	ITEM NO

ADDITIONAL INFORMATION		TYPE OF PRODUCT OR NAME OF CUSTOMER / PROJECT	
STATUS OF DRAWING		VM-12 (BT-2)	
DISTRIBUTION OF PRINTS		BHARAT HEAVY ELECTRICALS LTD SHYOPAL	
D.C.-1 S.W.-3 T.CK-1		NAME: S.S.A. D.O.B: S.S.A. APPL: J.S.P.	
REV DATE ALTERED CHECKED APPROVED 01 09.1.05 09.1.05 09.1.05 09.1.05		SCALE: 1:1 WEIGHT: (K.G.) REF. TO ASSY. DRG. NO. 001 ITEM NO. 005	
ZONE ASSY. CORRECTED AS PER ITEM 001 (DCA-22137)		DRAWING NO. 15219002508 SHEET NO. 01 NO. OF SHEETS 01	

REV	DATE	ALTERED CHECKED APPROVED	REV	DATE	ALTERED CHECKED APPROVED	REV	DATE	ALTERED CHECKED APPROVED	REV	DATE	ALTERED CHECKED APPROVED	REV	DATE	ALTERED CHECKED APPROVED	REV	DATE	ALTERED CHECKED APPROVED