

DRG. NO. 25219002522

WT. OF CPR. FOR :-

- VAR-00 - 3.088 KG.
- VAR-01 - 2.712 KG.
- VAR-02 - 4.934 KG.
- VAR-03 - 4.934 KG.

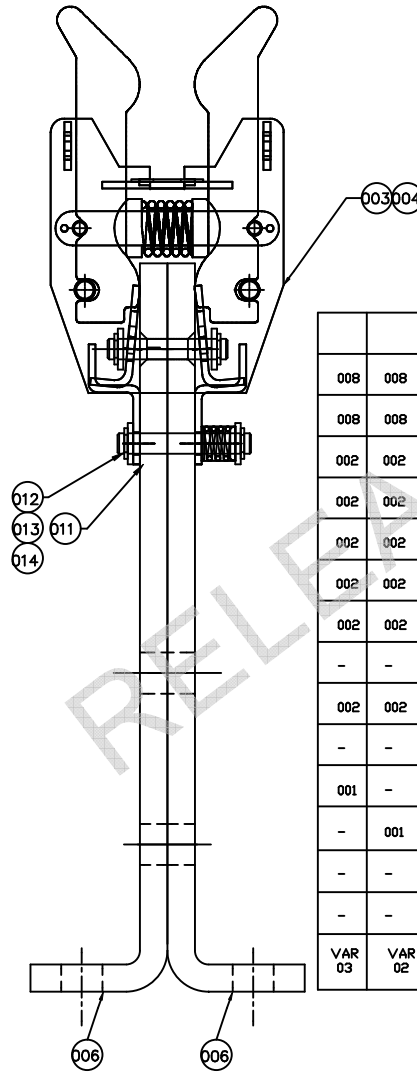
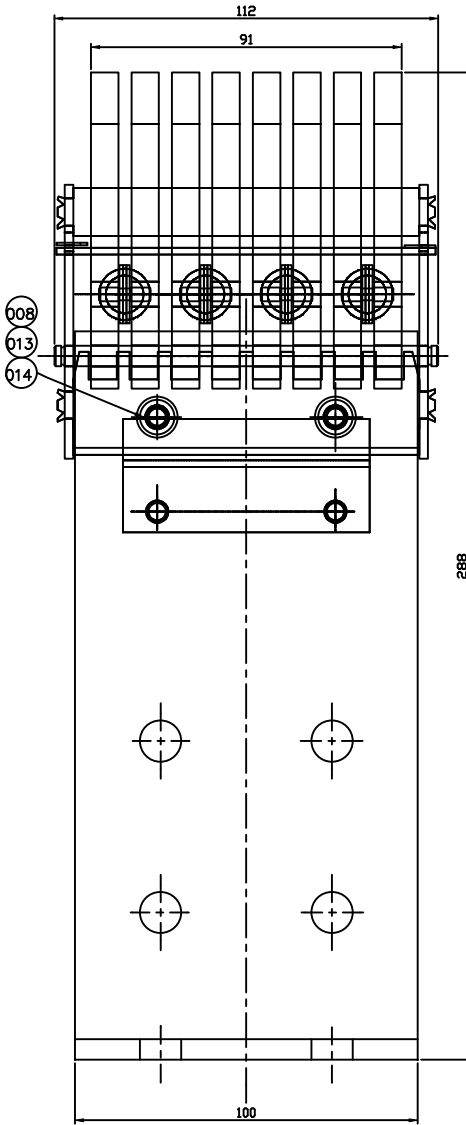

| REV. | DATE | ALTERED | SUS | REMARKS | VAR. NO. | ITEM NO. | DESCRIPTION | DRAWING NO. | QTY. | UNIT | WT. |
|--------|--------|---------|-------|---------|----------|----------|-----------------------|-------------|------|------|-------|
| 008 | 008 | 008 | 008 | | | 014 | CIRCLIP C5-ST | | | | |
| | | | | | | | | AA7167006 | | | |
| 008 | 008 | 008 | 008 | | | 013 | WASHER MCD 6.4-ST | | | | |
| | | | | | | | | AA7167006 | | | |
| 002 | 002 | | | | | 012 | GROOVE PIN | 45211001727 | 007 | | |
| 002 | 002 | 002 | 002 | | | 011 | GROOVE PIN | 45211001727 | 006 | | |
| 002 | 002 | 002 | 002 | | | 010 | SPRING | 35211001730 | 001 | | |
| 002 | 002 | 002 | 002 | | | 009 | CATCH | 35211001734 | 001 | | |
| 002 | 002 | | | | | 008 | GROOVE PIN | 45211001727 | 004 | | |
| - | - | 002 | 002 | | | 007 | GROOVE PIN | 45211001727 | 005 | | |
| 002 | 002 | | | 16TK | | 006 | TOP FIXED CONNECTION | 35219005500 | 002 | | 1.715 |
| | | | | | | | | | | | 001 |
| - | - | 002 | 002 | 12TK | | 005 | TOP FIXED CONNECTION | 35219005500 | 001 | | 0.980 |
| | | | | | | | | | | | 001 |
| 001 | - | - | - | | | 004 | PLUG IN CONTACT ASSY. | 35211001721 | 01 | | |
| - | 001 | - | - | | | 003 | PLUG IN CONTACT ASSY. | 35211001721 | 02 | | |
| - | - | 001 | - | | | 002 | PLUG IN CONTACT ASSY. | 35211001721 | 03 | | |
| - | - | - | 001 | | | 001 | PLUG IN CONTACT ASSY. | 35211001721 | 04 | | |
| VAR 03 | VAR 02 | VAR 01 | VAR00 | | | | | | | | |

VAR. 02 & 03
(2NOS.-8TK. x 100 WIDE CONNECTOR)

INVENTORY NO. SIGN AND DATE

REF. DRG. NO.

REV. DATE

| REV. | DATE | ALTERED | SUS | REMARKS | VAR. NO. | ITEM NO. | DESCRIPTION | DRAWING NO. | QTY. | UNIT | WT. |
|------|--------|------------------|----------|---------------------------------------|----------|----------|-------------|-------------|------|------|-----|
| 04 | 0.8.10 | CHECKED APPROVED | K.S.MANI | | | | | | | | |
| | | | MAK | | | | | | | | |
| | | | | WTY. FOR CPR. FOR VAR. 00 TO 03 ADDED | | | | | | | |
| | | | | | | | | | | | |
| | | | | (DCA NO.29914) | | | | | | | |
| 03 | 6.3.06 | CHECKED APPROVED | K.S.MANI | | | | | | | | |
| | | | MAK | | | | | | | | |
| | | | | VAR. DESCRIPTION MODIFIED | | | | | | | |
| | | | | | | | | | | | |
| | | | | (DCA NO.25317) | | | | | | | |
| 02 | 7.3.06 | CHECKED APPROVED | K.S.MANI | | | | | | | | |
| | | | MAK | | | | | | | | |
| | | | | AMP. RATING REMOVED | | | | | | | |
| | | | | | | | | | | | |
| | | | | (DCA-25290) | | | | | | | |
| 01 | 4.3.06 | CHECKED APPROVED | K.S.MANI | | | | | | | | |
| | | | MAK | | | | | | | | |
| | | | | VIEW CORRECTED | | | | | | | |
| | | | | | | | | | | | |
| | | | | (DCA-25275) | | | | | | | |

| | | | |
|---|--|--|--|
| ADDITIONAL INFORMATION STATUS OF DRAWING B DISTRIBUTION OF PRINTS O/C -1 TCX -1 SWM -3 | | 3 पत्र का प्रकार या ग्राहक/परियोजना का नाम TYPE OF PRODUCT OR NAME OF CUSTOMER/PROJECT VM-12 (BT-II) | |
| भारत हेवी इलेक्ट्रिकल्स लिमिटेड BHARAT HEAVY ELECTRICALS LTD. BHOPAL | | जर्मनी/सिग. S.S.S. 29.12.01 S.S.A. 29.12.01 J.S.P. 29.12.01 | |
| DEPT/SWE UNTOL. DIMS. GR. CODE AA 0230208 | | उद्योग का नाम REF. TO ASSY. DRG. 25219002522 | |
| TOP CONTACT ASSY. | | ड्राइंग का नंबर 25219002522 | |