



**PRODUCT STANDARD  
SWITCHGEAR ENGINEERING DIVISION**

SG 24312 Rev 00

**PAGE 1 OF 3**

**Integrated Voltage Indication system for 36kV GIS**

**1.0 Application:**

Integrated Voltage indication system is used for indicating the continuous voltage indication of power cable and bushing used in the switchgear application This voltage detecting system is maintenance-free, reliable and cost effective.

**2.0 Scope of Supply**

Item No	Item
001	VOLTAGE DETECTION SYSTEM WITH RELAYS
002	VOLTAGE DETECTION SYSTEM WITHOUT RELAYS
003	CABLE SET 1 m + 1.5 m + 2.25 m + 0.3 m GREEN-YELLOW EARTHING CABLE

**3.0 Specification and vendor compliance**

Sl. No	Description	Data	Supplier compliance
<b>1</b>	<b>Voltage detection system with Relay</b>		
1.1	System voltage(phase to phase)	33kV	
1.2	Frequency	50Hz	
1.3	Threshold Voltage	4 to 5V	
1.4	Type of Protection	IP54	
1.5	Operating temperature	-5 to 60°C	
1.6	power supply: External or No external power supply required	48V DC	
1.7	<b>Relay Contact</b> Two change over Contact C-NC-NO As per connection diagram fig a.	C/O Potential free	
1.8	Red LCD display		
1.9	Test sockets available for phase comparison		
1.10	Additional third socket for testing the integrated LCD display		
1.11	Secure cover for sockets		
1.12	Sensible test process using three feeler pins		
1.13	Integrated breaking point for voltage-limiting		

**COPYRIGHT AND CONFIDENTIAL**

The information on this document is the property of Bharat Heavy  
Electricals Limited

It must not be used directly or indirectly in any way detrimental to interest

<b>REV.</b>	00	<b>PRINTS TO:-</b>	<b>APPROVED –</b>		
<b>ALTD.</b>	AK		HRP		
<b>APPD.</b>	HRP		<b>PREP ARED</b>	<b>ISSU ED</b>	<b>DATE</b>
<b>DATE.</b>	02.06.15		AK	VD	02.06.2015



**PRODUCT STANDARD**  
SWITCHGEAR ENGINEERING DIVISION

SG 24312 Rev 00

**PAGE 2 OF 3**

**COPYRIGHT AND CONFIDENTIAL**

The information on this document is the property of Bharat Heavy Electricals Limited

It must not be used directly or indirectly in any way detrimental to interest of Co.

Sl. No	Description	Data	Supplier compliance
1.14	No in-service test required		
1.15	<b>Connected with Size 2 connex</b> bushing with voltage tap via suitable matching cable 3 x RG58 coaxial cable with 3 x flat sleeve-connector 4.8x0.8 mm to connect with size 2 bushing		
1.16	Confirm to the Connection arrangement as shown in fig a.		
<b>2</b>	<b>Voltage detection system without Relay</b>		
2.1	System voltage(phase to phase)	33kV	
2.2	Frequency	50Hz	
2.3	Threshold voltage	4 to 5V	
2.4	Type of Protection	IP66	
2.5	Operating temperature	-5 to 55°C	
2.6	Red LCD display		
2.7	Test sockets available for phase comparison		
2.8	Additional third socket for testing the integrated LCD display		
2.9	Secure cover for sockets		
2.10	Sensible test process using three feeler pins		
2.11	Integrated breaking point for voltage-limiting		
2.12	No in-service test required		
2.13	<b>Connected with Size 2 connex</b> bushing with voltage tap via suitable matching cable 3 x RG58 coaxial cable with 3 x flat sleeve-connector 4.8x0.8 mm to connect with size 2 bushing		
2.14	Confirm to the Connection arrangement as shown in fig a.		
3.0	Dimensions	100mm(Max) X 50mm(Max) X 200mm(Max)	

<b>REV.</b>	00	<b>PRINTS TO:-</b>	<b>APPROVED –</b>		
<b>ALTD.</b>	AK		HRP		
<b>APPD.</b>	HRP		<b>PREPARED</b>	<b>ISSUED</b>	<b>DATE</b>
<b>DATE.</b>	02.06.15		AK	VD	02.06.2015



***Fig a - Voltage detection system with Relay***

VDS connecting diagram for GIS

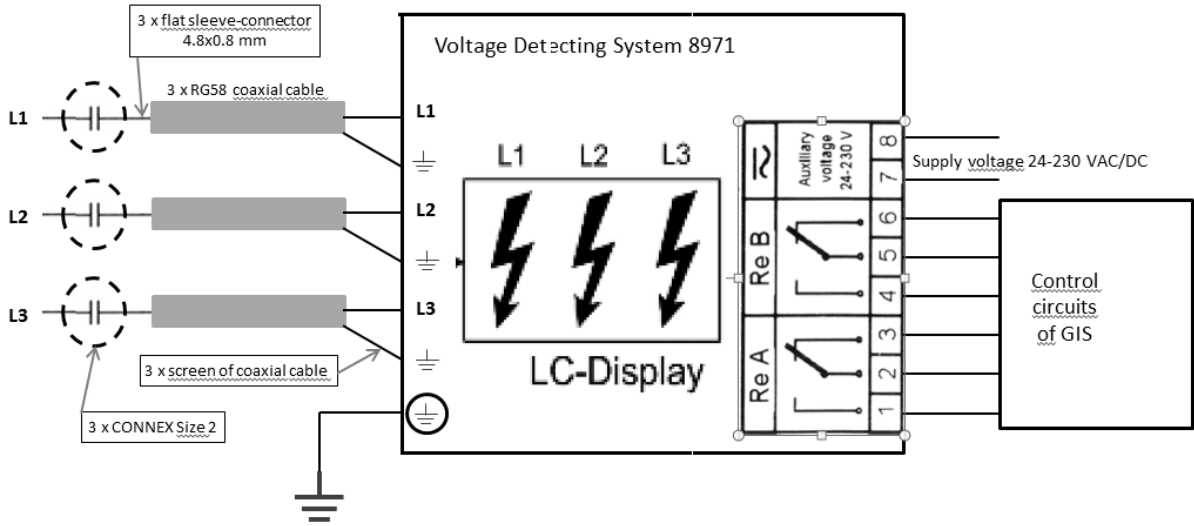

***Fig b - Voltage detection system without Relay***

VDS connecting diagram for GIS

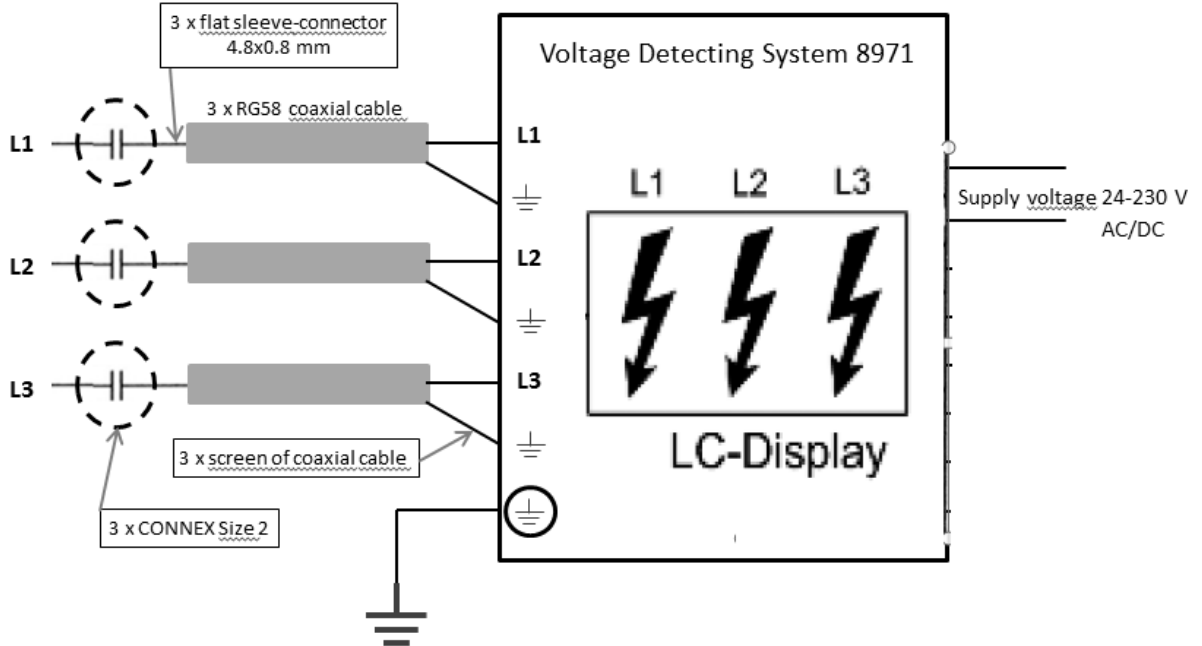

**COPYRIGHT AND CONFIDENTIAL**

The information on this document is the property of Bharat Heavy Electricals Limited  
It must not be used directly or indirectly in any way detrimental to interest

<b>REV.</b>	00	<b>PRINTS TO:-</b>	<b>APPROVED -</b>		
<b>ALTD.</b>	AK				
<b>APPD.</b>	HRP		<b>PREP</b>	<b>ISSU</b>	<b>DATE</b>
<b>DATE.</b>	02.06.15		<b>ARED</b>	<b>ED</b>	
			AK	VD	02.06.2015