

2



HYDRO TURBINE ENGINEERING DIVISION

SPECIFICATION NO.

REV. NO.
00

120270024

TITLE: 3/8" BSP MALE-FEMAIL SNUBBER
FOR PRESSURE GAUGE

PAGE : 01 OF 01

Application

This Snubber device is used as a Damping device / Surge protector device to avoid damage of Pressure Gauge during sudden surges of oil/water/air when any hydraulic /pneumatic system is operated in any abnormal condition. Snubber must have equipped with air vent screw provision. Refer sketch no.

HTE/GC/351

Technical Specification

- 1. Type of Device : Snubber
- 2. Application : Pneumatic/oil/Water
- 3. Material : S.S.ASTM-316/304
- 4. outlet connection : 3/8" BSP(Male) parallel
- 5. Inlet connection : 3/8" BSP(Female) parallel
- 6. Working pressure : 120 Kg/cm²
- 7. Body test pressure : 180 Kg/cm²(Hydraulic)
- 8. Working Temperature : (-)10 to 80 degree centigrade

Technical Requirement

- a. Mechanical & chemical test certificate must be of NABL approved lab.
- b. Threads must be complying to Go & No-go gauge (parallel).
- c. 10% of quantity must be approved by our BHEL Bhopal QC (WTM) to be supplied at BHEL Bhopal works before start manufacturing in bulk. Material must be inspected by BHEL approved third party inspection agency at supplier works before dispatch as per P.O.

Identification

- Each Snubber must be engraved with size & P.O.no

Guarantee Certificate:

- The Snubber supplied shall be guaranteed for 18 months from the date of supply.

REV. NO.		DISTRIBUTION	QTY	APPROVED					
PRD.				-----sd-----					
CKD				HPE	01	PREPARED	CHECKED	ISSUED	DATE
APPED				MM(H)	04				
DATE						-----sd----- DH	-----sd----- VKN	-----sd----- PKB	01.11.17

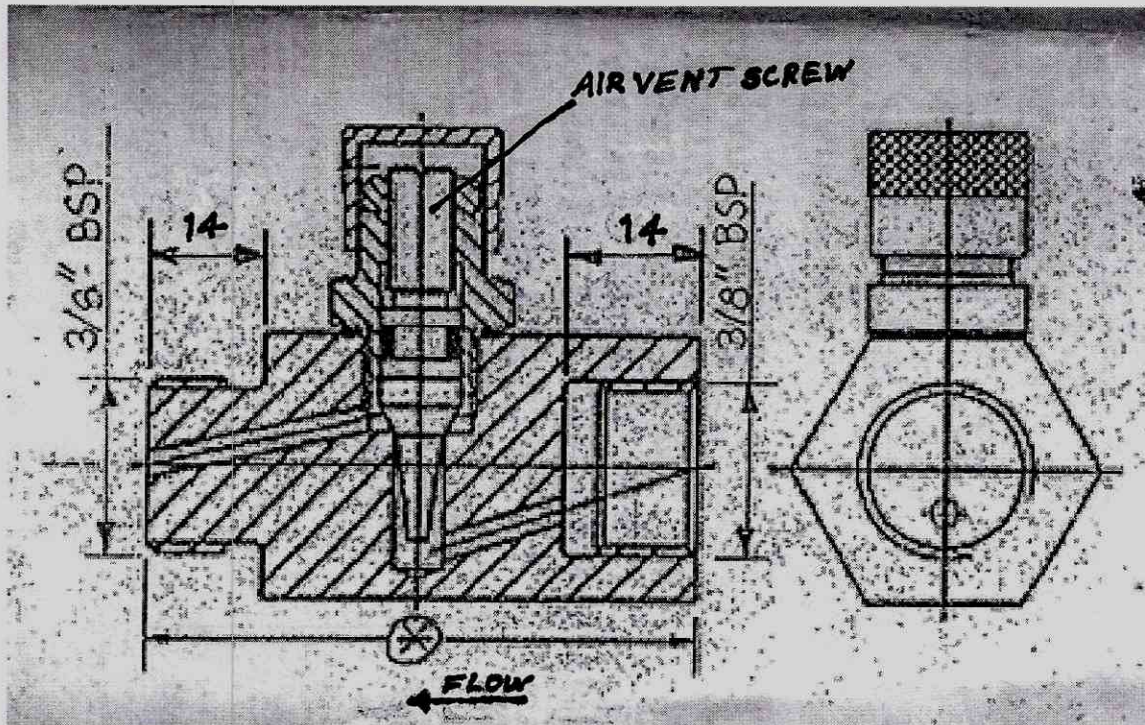
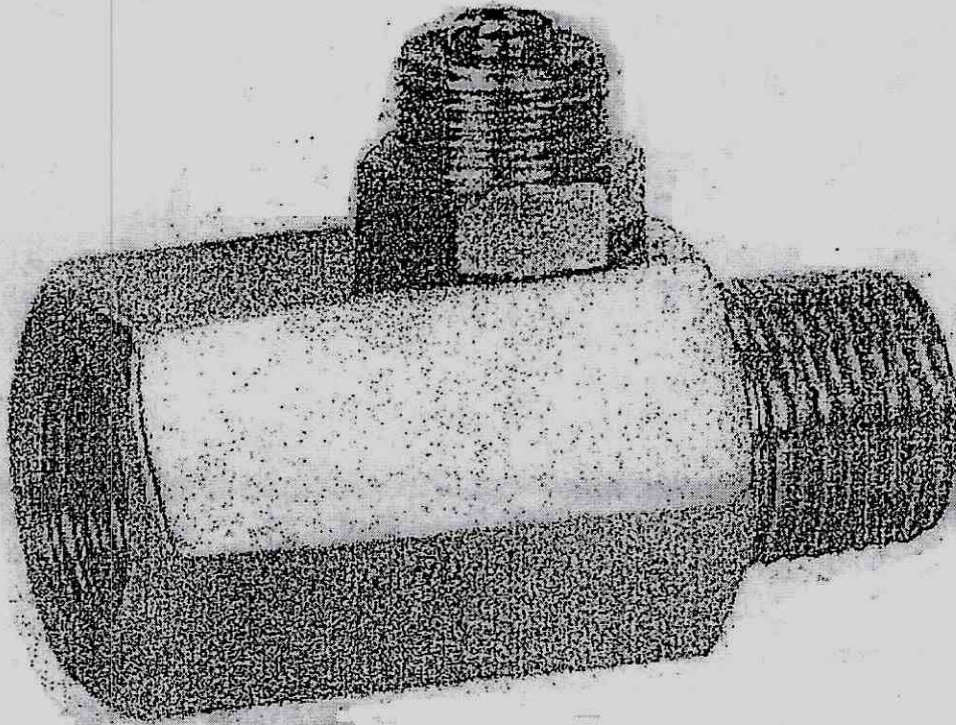

NOTE:-

- (1) DIMENTION MARKED THUS  TO BE FURNIST BY VENDOR.
- (2) DRG.SHOWN IS TENTATIVE & REFRENCE PURPOSE.

PRESSURE GAUGE SNUBBER

SKETCH NO.

HTE/GC/351

REV. 02