

ANGLE PROJECTION

(ALL DIMENSIONS ARE IN mm)

①

DRG. NO. 3 205 01 150 17

TECHNICAL REQUIREMENTS:-

1. MATERIAL:- STAINLESS STEEL CASTING TO AA 19542
2. MACHINING:- CASTING TO BE SUPPLIED IN ROUGH MACHINED CONDITION TO THE DIMENSIONS GIVEN IN THE DRG, LEAVING NO FURTHER ALLOWANCE. FINISH OF THE ROUGH MACHINED SURFACES TO BE 12.5 MICRON OR BETTER.
3. NDT:-
 - (i). MEGNAFLUX TESTING TO ASTM E 125 LEVEL-2 FOR LINEAR INCLUSIONS OR CRACKS.
 - (ii). ULTRASONIC TESTING TO ASTM A-609 LEVEL-2.
4. CASTING TO BE FREE FROM ALL CASTING DEFECTS.
5. TEST PIECES TO BE CAST INTEGRAL WITH THE CASTING & TO BE REMOVED IN THE PRESENCE OF BHEL'S INSPECTOR.

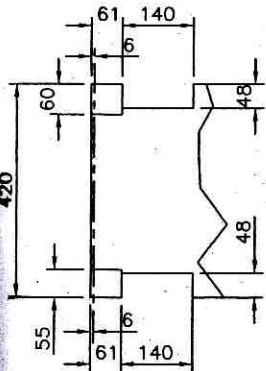
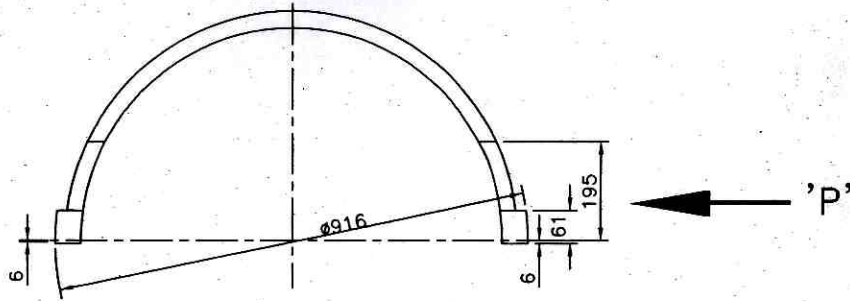
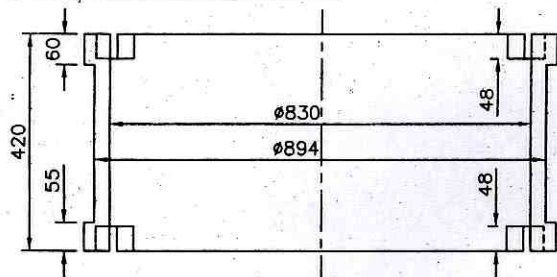





VIEW FROM 'P'

001				SHAFT SLEEVE HALF (CASTING)				146.0															
AA 19542				002																			
59	64	65	75	78	79	25	27	29	58	59	60	77	29	31	34	45	55	56	57	58	65	72	
VAR.00		REMARKS		VAR. NO.		ITEM NO.		DESCRIPTION		STD.		DRAWING NO.		MATL. CODE		MATL. SPCN.		UNIT		UNIT WT.		QTY.	

28 - CARD TYPE-3

28 - CARD TYPE-1

28 - CARD TYPE-2

DRAWING REVIEW				ADDITIONAL INFORMATION				TYPE OF PRODUCT OR NAME OF CUSTOMER/PROJECT							
DEPT.	NAME	SIGN.	DATE	STATUS OF DRAWING U				NAGJHARI / KALINADI							
				DISTRIBUTION OF PRINTS				 BHARAT HEAVY ELECTRICALS LTD. BHOPAL							
				HTE-2 THX-1 WTM-5											
DRN	RKS		30.3.13	NO. OF VAR.				30.03.13							
CKD	A.M.		30.03.13												
APPD	J.S.H.		30.03.13												
DATE	ALTERED CHECKED APPD.	REV.	DATE	ALTERED CHECKED APPD.	REV.	DATE	ALTERED CHECKED APPD.	DEPT. H.T.E. CODE 402	UNTOL. DIMS. GR. 32000049014		SCALE 1:20	WEIGHT(K.G.) 146	REF.TO ASSY.DRG. G 3740146	ITEM NO.	NO. OF ITEM
								TITLE SHAFT SLEEVE HALF (CASTING)				DRAWING NO. 3 205 01 150 17			
												SHT. NO. 01		NO. OF SHT. 01	

A3 SIZE